

EPSON TERMINAL PRINTER

EPSON/Stylus Color 200
EPSON/Stylus 200

SERVICE MANUAL

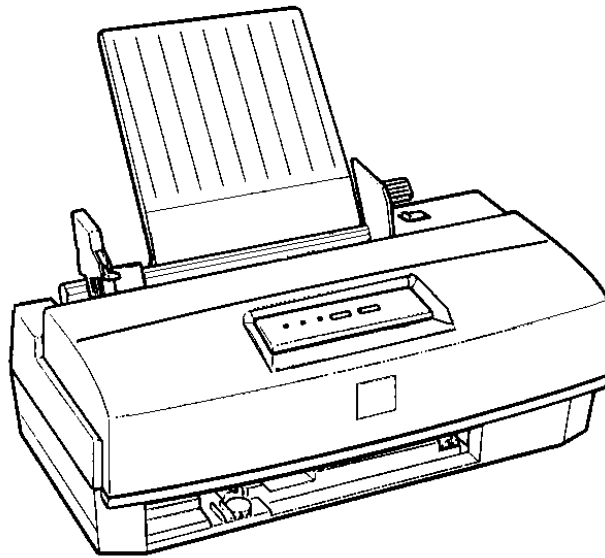

EPSON

Rev.A
4006645

NOTICE

All rights reserved. Reproduction of any part of this manual in any form whatsoever without SEIKO EPSON's express written permission is forbidden.

The contents of this manual are subjects to change without notice.

All efforts have been made to ensure the accuracy of the contents of this manual. However, should any errors be detected, SEIKO EPSON would greatly appreciate being informed of them.

The above notwithstanding SEIKO EPSON can assume no responsibility for any errors in this manual or the consequence thereof.

Epson and Epson's ESC/P are registered trademark of Seiko Epson Corporation.

General Notice: Other product names used herein are for identification purpose only and may be trademark of their respective companies.

+ Copyright 1995 by SEIKO EPSON CORPORATION Nagano, Japan

PRECAUTIONS

Precautionary notations throughout the text are categorized relative to 1) personal injury and 2) damage to equipment.

DANGER Signals a precaution which, if ignored, could result in serious or fatal personal injury. Great caution should be exercised in performing procedures preceded by DANGER Headings.

WARNING Signals a precaution which, if ignored, could result in damage to equipment.

The precautionary measures itemized below should always be observed when performing repair/maintenance procedures.

DANGER

1. ALWAYS DISCONNECT THE PRODUCT FROM THE POWER SOURCE AND PERIPHERAL DEVICES PERFORMING ANY MAINTENANCE OR REPAIR PROCEDURE.
2. NOWORK SHOULD BE PERFORMED ON THE UNIT BY PERSONS UNFAMILIAR WITH BASIC SAFETY MEASURES AS DICTATED FOR ALL ELECTRONICS TECHNICIANS IN THEIR LINE OF WORK.
3. WHEN PERFORMING TESTING AS DCTATED WITHIN THIS MANUAL, DO NOT CONNECT THE UNIT TO A POWER SOURCE UNTIL INSTRUCTED TO DO SO. WHEN THE POWER SUPPLY CABLE MUST BE CONNECTED, USE EXTREME CAUTION IN WORKING ON POWER SUPPLY AND OTHER ELECTRONIC COMPONENTS.

WARNING

1. REPAIRS ON EPSON PRODUCT SHOULD BE PERFORMED ONLY BY AN EPSON CERTIFIED REPAIR TECHNICIAN.
2. MAKE CERTAIN THATTHE SOURCE VOLTAGES IS THE SAME AS THE RATED VOLTAGE, LISTED ON THE SERIAL NUMBER/RATING PLATE. IF THE EPSON PRODUCT HAS A PRIMARY AC RATING DIFFERENT FROM AVAILABLE POWER SOURCE, DO NOT CONNECT IT TO THE POWER SOURCE.
3. ALWAYS VERIFY THAT THE EPSON PRODUCT HAS BEEN DISCONNECTED FROM THE POWER SOURCE BEFORE REMOVING OR REPLACING PRINTED CIRCUIT BOARDS AND/OR INDIVIDUAL CHIPS.
4. IN ORDER TO PROTECT SENSITIVE MICROPROCESSORS AND CIRCUITRY, USE STATIC DISCHARGE EQUIPMENT,SUCH AS ANTI-STATIC WRIST STRAPS, WHEN ACCESSING INTERNALCOMPONENTS.
5. REPLACE MALFUNCTIONING COMPONENTS ONLY WITH THOSE COMPONENTS BY THE MANUFACTURE; INTRODUCTION OF SECOND-SOURCE ICs OR OTHER NONAPPROVED COMPONENTS MAY DAMAGE THE PRODUCT AND VOID ANY APPLICABLE EPSON WARRANTY.

PREFACE

This manual describes functions, theory of electrical and mechanical operations, maintenance, and repair of Epson Stylus Color 200 /Epson Stylus 200.

The instructions and procedures included herein are intended for the experience repair technician, and attention should be given to the precautions on the preceding page. The chapters are organized as follows:

CHAPTER 1. PRODUCT DESCRIPTION

Provides a general product overview, lists specifications, and illustrates the main components of the printer.

CHAPTER 2. OPERATING PRINCIPLES

Describes the theory of printer operation.

CHAPTER 3. DISASSEMBLY AND ASSEMBLY

Includes the step-by-step guide for product disassembly and assembly

CHAPTER 4. ADJUSTMENTS

Includes a step-by-step guide for adjustment.

CHAPTER 5. TROUBLESHOOTING

Provides Epson-approved techniques for adjustment.

CHAPTER 6. MAINTENANCE

Describes preventive maintenance techniques and lists lubricants and adhesives required to service the equipment.

APPENDIX

Describes connector pin assignments, circuit diagrams, circuit board component layout and exploded diagram.

The contents of this manual are subject to change without notice.

REVISION SHEET

Revision	Issue Date	Contents
Rev.-A	July 15,1996	1st issue

TABLE OF CONTENTS

CHAPTER 1.	PRODUCT DESCRIPTION
CHAPTER 2.	OPERATION PRINCIPLES
CHAPTER 3	DISASSEMBLY AND ASSEMBLY
CHAPTER 4.	ADJUSTMENT
CHAPTER 5.	TROUBLESHOOTING
CHAPTER 6.	MAINTENANCE
APPENDIX	

Chapter 1 Product Description

Table of Contents

1.1 OVERVIEW	1-1
<hr/>	
1.2 SPECIFICATIONS	1-2
1.2.1 Printing Specifications	1-2
1.2.2 Paper Handling Specifications	1-4
1.2.3 Paper Specifications	1-4
1.2.4 Ink Cartridge Specifications	1-6
1.2.5 Electrical Specifications	1-7
1.2.6 Environmental Conditions	1-7
1.2.7 Reliability	1-8
1.2.8 Safety Approvals	1-8
1.2.9 Acoustic Noise	1-8
1.2.10 Physical Specifications	1-8
<hr/>	
1.3 INTERFACE SPECIFICATIONS	1-9
1.3.1 Parallel Interface Specifications	1-9
1.3.2 Parallel Interface (Reverse channel)	1-11
<hr/>	
1.4 OPERATIONS	1-12
1.4.1 Control Panel	1-12
1.4.2 Panel Operation and Built-in Function	1-12
1.4.3 Default Settings	1-14
1.4.3.1 Default Settings Items	1-14
1.4.3.2 Changing the Default Settings	1-15
1.4.4 Error Conditions	1-16
1.4.5 Printer Initialization	1-16
1.4.5.1 Power-On Initialization	1-16
1.4.5.2 Software Initialization	1-16
1.4.5.3 Panel Initialization	1-16
<hr/>	
1.5 MAIN COMPONENTS	1-17
1.5.1 Main Control Board(C199 Main Control Board)	1-17
1.5.2 Power Supply Board(C160 PSB/PSE Board)	1-18
1.5.3 C160 I/F Board	1-18
1.5.4 Printer Mechanism((M-4C11)	1-19
1.5.5 Housing	1-19

List of Figures

Figure 1-1. Exterior View of EPSON Stylus Color 200	1-1
Figure 1-2. Nozzle Configuration	1-2
Figure 1-3. Printable Area	1-4
Figure 1-4. Paper Select Lever	1-5
Figure 1-5. Temperature / Humidity of Range	1-7
Figure 1-6. Data Transmission Timing	1-9
Figure 1-7. Control Panel Appearance	1-12
Figure 1-8. C199 Main Control Board Component Layout	1-17
Figure 1-9. C160 PSB/PSE Board Component Layout	1-18
Figure 1-10. C160 I/F Board Component Layout	1-18
Figure 1-11. M-4C11 Printer Mechanism	1-19
Figure 1-12. Housing	1-19

List of Tables

Table 1-1. Print Speed and Printable Columns	1-2
Table 1-2. Character Tables	1-3
Table 1-3. Paper Specifications	1-4
Table 1-4. Adjust Lever Settings	1-5
Table 1-5. Paper Select Lever Settings	1-5
Table 1-6. Black I/C Specifications	1-6
Table 1-7. Color I/C Specifications	1-6
Table 1-8. Rated Electrical Ranges	1-7
Table 1-9. Acceptable Environmental Conditions	1-7
Table 1-10. Signal and Connector Pin Assignment for Parallel I/F	1-10
Table 1-11. Pin Assignment for Reverse channel	1-11
Table 1-12. Panel Operation	1-12
Table 1-13. Built-in Functions on the Panel	1-13
Table 1-14. Button Operations in Default Setting Mode	1-13
Table 1-15. Error Indications	1-13
Table 1-16. Default Setting Items	1-14
Table 1-17. Default Setting Items(Con.)	1-15
Table 1-18. Language Selection	1-15

1.1 FEATURES

The Epson Stylus Color 200/Epson Stylus 200 printer are color ink jet dot matrix printers that come with a 64-nozzle black printhead and a 60-nozzle CMY color printhead, either of which can be installed in the printer. The Epson Stylus 200 version comes standard with only the 64-nozzle black printhead; however, the CMY color printhead can be purchased as an optional upgrade. Whenever this manual mentions the Epson Stylus Color 200, its descriptions are equally applicable to the Epson Stylus 200. The major printer features are:

- ❑ High-quality color print
 - 720 dpi printing
 - 720 dpi printing on plain paper
 - 720, 360 dpi printing on special coated paper
(Use the monochrome head only with plain paper)
 - ❑ High-speed print(10CPI)
 - Monochrome head: 125cps (LQ)
167cps(HS)
 - CMY head: 200cps(LQ/one-pass printing)
- Note: The CMY head prints 360 dpi printing in three passes.
- ❑ Built-in auto sheet feeder
 - Cut sheets
 - Transparency films (A4 and letter)
 - Envelopes (10 sheets)
 - Plain papers (100 sheets,64g/m2)
 - ❑ Built-in I/F
 - Parallel I/F only (8-bit parallel: IEEE P1284 mode)
 - ❑ Easy setup
 - No DIP switches
 - ❑ 3 scalable fonts and 3 LQ fonts standard
 - Roman T, Sans Serif H, Roman, Sans Serif (scalable)
 - Roman, Sans Serif, Courier, (bitmapLQ)
 - ❑ Character tables
 - 9 character tables (standard version)
 - 15 character tables (NLSP version)
 - ❑ Low running cost

The figure below shows the EPSON Stylus Color 200.

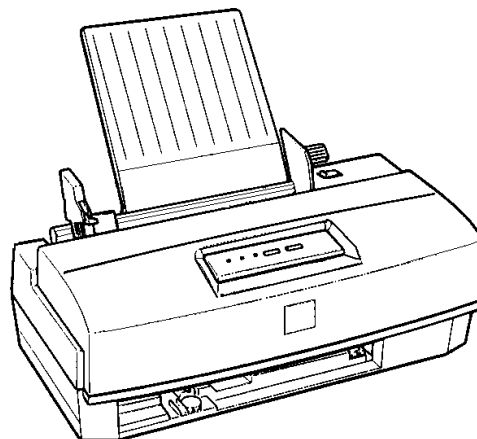

Figure 1-1. Exterior Viewing of EPSON Stylus Color 200

1.2 SPECIFICATIONS

This section provides statistics and other detailed information for the printer.

1.2.1 Printing Specifications

Print system: On-demand ink jet system
 Nozzle configuration: 64 nozzles (10 × 2 + 11 × 4 standard): monochrome
 60 nozzles (20 × 3 standard): color

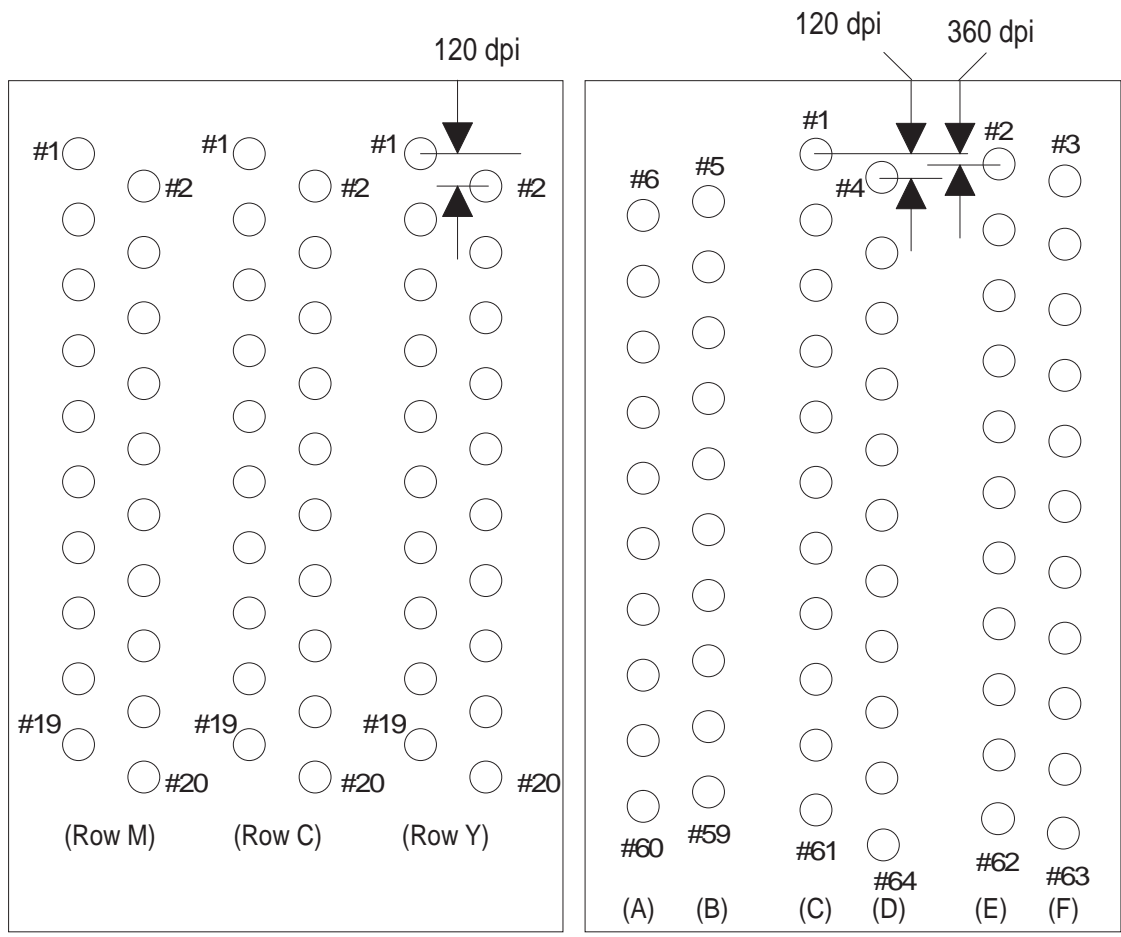

Figure1-2. Nozzle Configuration

Printing direction: Bidirectional with logic-seeking

Table 1-1. Print Speed and Printable Columns

Character Pitch	Printable Columns	Printing Speed (cps)		
		Monochrome (Normal)	Monochrome (Draft)	CMY
10 cpi (Pica)	80	125	167	200
12 cpi (Elite)	96	150	200	240
15 cpi	120	188	250	300
17 cpi (Pica condensed)	136	214	285	342
20 cpi (Elite condensed)	160	250	333	400

Character tables: Legal and 14 international sets

Table 1-2. Character Tables

Character Tables		Bitmap Fonts	Scalable Fonts	
		EPSON Roman EPSON Sans Serif EPSON Courier	EPSON Roman EPSON Sans Serif	EPSON Roman T EPSON Sans Serif H
Standard	Italic	Supported	Supported	Supported
	PC437 (U.S./Standard Europe)			
	PC850 (Multilingual)			
	PC860 (Portuguese)			
	PC861 (Icelandic)			
	PC863 (Canadian-French)			
	PC865 (Nordic)			
	Abicomp			
BRASCI				
NLSP	Italic	Supported	Supported	Supported
	PC437 (U.S./Standard Europe)			
	PC850 (Multilingual)			
	PC437 (Greek)	Supported	Supported	Not supported
	PC852 (East Europe)			
	PC853 (Turkish)			
	PC855 (Cyrillic)			
	PC857 (Turkish)			
	PC866 (Russian)			
	PC869 (Greek)			
	MAZOWIA (Poland)			
	Code MJK (Czecho/Slovakia)			
	ISO 8859-7 (Latin/Greek)			
	ISO Latin 1T (Turkish)			
	Bulgaria (Bulgaria)			

Fonts: Bitmap LQ fonts
 - EPSON Roman (10 cpi/12 cpi/15 cpi/Proportional)
 - EPSON Sans Serif (10/12/15/Proportional)
 - EPSON Courier (10/12/15)

Scalable fonts
 - EPSON Roman 10.5 points, 8 ~ 32 points (in units of 2 points)
 - EPSON Sans Serif 10.5 points, 8 ~ 32 points (in units of 2 points)
 - EPSON Roman T 10.5 points, 8 ~ 32 points (in units of 2 points)
 - EPSON Sans Serif H 10.5 points, 8 ~ 32 points (in units of 2 points)

Control codes: ESC/P 2 and expanded raster graphics codes

Input data buffer: 2.5Kbyte to 15Kbyte

1.2.2 Paper Handling Specifications

Feeding method: Friction feed paper is fed from the built-in auto sheet feeder (ASF).
 Line spacing: 1/6 inch feed or programmable in 1/360 inch minimum increments.
 Paper path: Cut sheets are fed from the built-in auto sheet feeder (ASF).
 Top in and front out.
 Feeding speed: 102 msec. (at 1/6-inch feed pitch).

1.2.3 Paper Specifications

Table 1-3. Paper Specifications

		Cut Sheets			Envelopes	+
^		Transparencies				^
^		A4	Letter	Legal	No. 10	DL
PW	Width	210 mm	216 mm	216 mm	240 mm	220 mm
PL	Length	297 mm	279 mm	358 mm	104 mm	110 mm
LM	Left margin	3 mm or more	3 mm or more	3 mm or more	3 mm or more	3 mm or more
RM	Right margin	3 mm or more	3 mm or more	10 mm or more	33.8 mm or more	13.8 mm or more
TM	Top margin	3 mm or more	3 mm or more	3 mm or more	3 mm or more	3 mm or more
BM	Bottom margin	14 mm or more	14 mm or more	14 mm or more	14 mm or more	14 mm or more

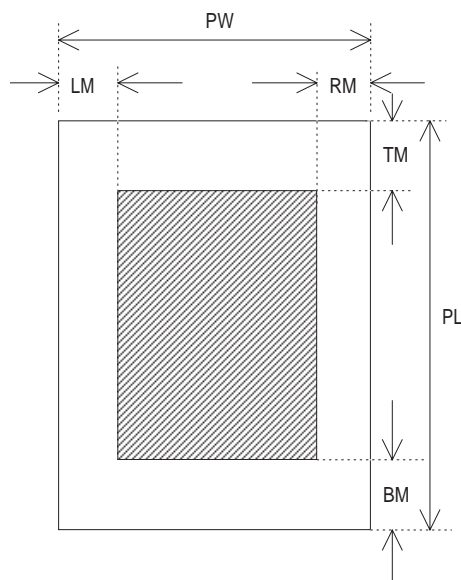

Figure 1-3. Printable Area

The adjust lever on the upper case must be set to the proper position for the paper thickness, as shown in Table 1-4.

Table 1-4. Adjust Lever Settings

Paper	Lever Position	Paper Thickness
Cut Sheets	Front (0 position)	0 mm
Envelops	Rear (+position)	0.62 mm

Also the paper select lever on the upper case must be set to the proper position for the paper varieties shown in Table 1-5.

Table 1-5. Paper Select Lever Settings

		Specifications for the Medium	+
<i>PF Mode</i>		Cut Sheets	Envelopes Postcards
^	Lever Position		
<i>ASF Feed</i>	Thick paper (Rear)	NO	OK
^	Thinner paper (Front)	OK	NO
<i>Manual Feed</i>	Thick paper (Rear)	OK	OK

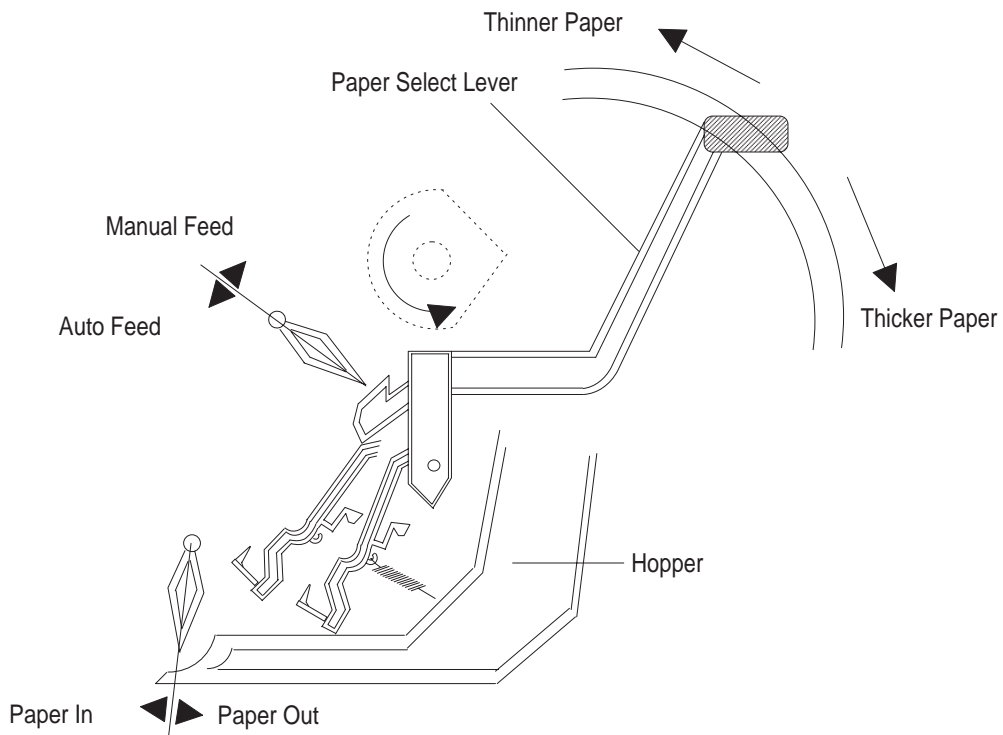

Figure 1-4. Paper Select Error

^	Thinner paper (Front)	NO	NO
---	-----------------------	----	----

Note: "OK" means paper can be used and "NO" means paper cannot.

1.2.4 Ink Cartridge Specifications

Table 1-6. Black I/C Specifications

<i>Item</i>	Specifications
<i>Type</i>	Exclusive cartridge
<i>Color and Weight</i>	Approximately 54 g (internal ink weight is 36 g \pm 0.5 g)
<i>Ink Life</i>	Black, High-quality ink produces 800 thousand characters
<i>Validity</i>	2 years (sealed in package) / 6 months (out of package)
<i>Storage Temperature</i>	<input type="checkbox"/> -30 to 40° C (-22 ~ 104° F) (Storage: a month or less at 40° C (104° F)) <input type="checkbox"/> -20 to 40° C (-15 ~ 104° F) (Transit: a month or less at 40° C (104° F)) <input type="checkbox"/> -30 to 60° C (-22 ~ 140° F) (Transit: 120 hours or less at 60° C (140° F))
<i>Dimensions</i>	30.0 (W) \times 58.0 (D) \times 38.5 \pm 0.3 (H) mm

Table 1-7. Color I/C Specifications

<i>Item</i>	Specifications
<i>Type</i>	Exclusive cartridge
<i>Color and Weight</i>	Cyan, Magenta, Yellow. Approximately 75 g (internal ink weight is 12.8 g \pm 0.5 g)
<i>Ink Life</i>	100% solid pattern: A4 — 16 sheets / each color
<i>Validity</i>	2 years (sealed in package) / 6 months (out of package)
<i>Storage Temperature</i>	<input type="checkbox"/> -30 to 40° C (-22 ~ 104° F) (Storage: a month or less at 40° C (104° F)) <input type="checkbox"/> -20 to 40° C (-15 ~ 104° F) (Transit: a month or less at 40° C (104° F)) <input type="checkbox"/> -30 to 60° C (-22 ~ 140° F) (Transit: 120 hours or less at 60° C (140° F))
<i>Dimensions</i>	42.9 (W) \times 56.5 (D) \times 38.5 \pm 0.3 (H) mm

1.2.5 Electrical Specifications

Table 1-8. Rated Electrical Ranges

Specification	120 V Version	220 - 240 V Version
Rated voltage	120 VAC	220 - 240 VAC
Input voltage range	103.5 ~ 132 V	198 ~ 264 V
Rated frequency range	50 ~ 60 Hz	50 ~ 60 Hz
Input frequency range	49.5 ~ 60.5 Hz	49.5 ~ 60.5 Hz
Rated current	0.5 A	0.3 A
Power consumption	Approx. 15 W (self-test with 10-cpi LQ characters)	Approx. 15 W (self-test with 10-cpi LQ characters)
Insulation resistance	10 M Ω , <i>minimum</i> (applying 500 VDC between AC line and chassis)	10 M Ω , <i>minimum</i> (applying 500 VDC between AC line and chassis)
Dielectric strength	1000 VAC rms for 1 minute or 1200 VAC rms for 1 second (between AC line and chassis)	1500 VAC rms for 1 minute (between AC line and chassis)

1.2.6 Environmental Conditions

Table 1-9. Acceptable Environmental Conditions

Condition	Operating	Non Operating
Temperature	10 ~ 35° C (50 ~ 95° F) ^{*1}	-20 ~ 60° C (-4 ~ 122° F) ^{*2}
Humidity	20 ~ 80% RH ^{*1, 3}	5 ~ 85% RH ^{*2, 3}
Shock resistance	1G (within 1 msec.)	2G (within 2 msec.) ^{*2}
Vibration resistance	0.15 G	0.50 G ^{*2}

^{*1} : For printer operation, conditions must be in the range shown in the figure below.

^{*2} : These conditions are applicable when the printer is in its shipping container.

^{*3} : Without condensation.

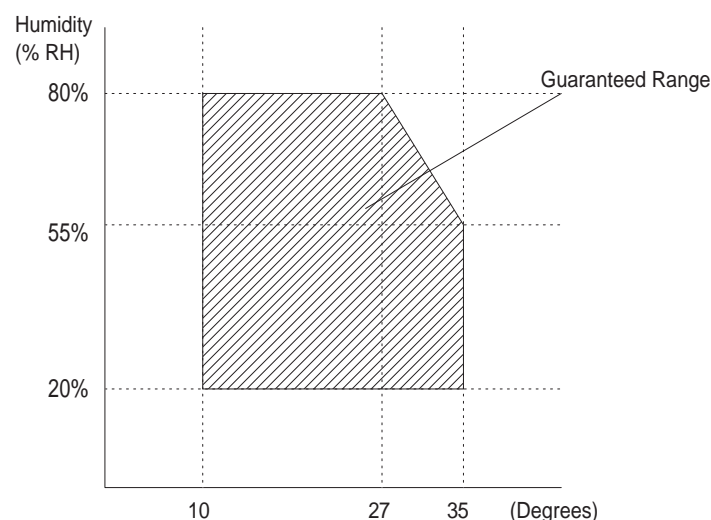

Figure 1-5. Temperature/Humidity of Range

1.2.7 Reliability

Total print volume:	25,000 pages (A4, letter)
MTBF:	4000 POH (Duty 7%)
MCBF:	1 million pass (except print head)
Printhead life:	1000 million dots/nozzle (color and monochrome)

1.2.8 Safety Approvals

Safety standards:	120 V version:	UL1950 with D3, CSA C22.2 # 950 with D3
	220-240 V version:	EN 60950 (TÜV, SEMKO, DEMKO, NEMKO, SETI)
Radio frequency interference (RFI):	120 V version:	FCC Part 15 Subpart B Class B
	220-240 V version:	Vfg.243 (VDE0878 part 3, part 30) EN55022 (CISPR PUB. 22) class B CSA C108.8

1.2.9 Acoustic Noise

Level:	Approximately 45 dB (A) (Per ISO 7779)
--------	--

1.2.10 Physical Specifications

Dimensions (W × D × H):	396.7 mm (W) × 205.6 mm (D) × 149.0 mm (H)
Weight:	About 3.9 kg (8.6 lb.), excluding head and ink cartridge

1.3 INTERFACE SPECIFICATIONS

The EPSON Stylus Color 200/EPSON Stylus 200 is standard-equipped with an 8-bit parallel and serial interface.

1.3.1 Parallel Interface Specifications (Forward Channel)

Data format:	8-bit parallel
Synchronization:	By $\overline{\text{STROBE}}$ pulse synchronization
Handshaking:	By BUSY and $\overline{\text{ACKNLG}}$ signals
Signal level:	TTL compatible level (IEEE-1284 level 1 device)
Adaptable connector:	36-pin 57-30360 (Amphenol) or equivalent
Data transmission timing:	See Figure 1-6.

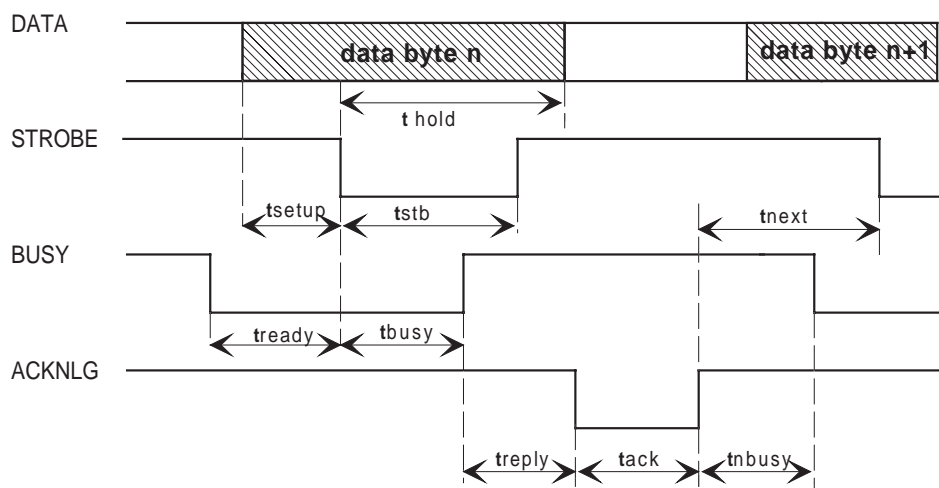

Figure 1-6. Data Transmission Timing

Note: Transition time (rise time and fall time) of every input signal must be less than 0.2 μs .

Parameter	Minimum	Maximum
tsetup	500 nsec	—
t hold	500 nsec	—
tstb	500 nsec	—
tready	0	—
tbusy	—	500 nsec
treply	—	—
tack	500 nsec	10 μs
tnbusey	0	—
tnext	0	—
ttout*	—	120 nsec
ttin**	—	200 nsec

* Rise and fall time of output signals

** Rise and fall time of input signals

Table 1-10 and 1-11 shows the connector pin assignments and signal functions of the 8-bit parallel interface.

Table 1-10. Signal and Connector Pin Assignments for Parallel Interface

Pin No.	Signal Name	I/O*	Description
1	-STROBE	I	Strobe pulse. Input data is latched at falling edge of the signal.
2-9	DATA 1-8	I	Parallel input data to the printer. bit 0:LSB
10	-ACKNLG	O	This signal (negative pulse) indicates that the printer has received data and is ready to accept next one.
11	BUSY	O	This signal's high level means that the printer is not ready to accept data.
12	PE	O	This signal's high level means that the printer is in a state of paper-out error.
13	SLCT	O	Always at high level when the printer is powered on.
14	-AFXT	I	Not used
31	-INIT	I	This signal's negative pulse initializes printer.
32	-ERROR	O	This signal's low level means the printer is in a state of error.
35	+5 V	—	Pulled up to +5 V through 1.0 K Ω resistor in the printer.
36	-SLIN	In	Not used.
17	CHASSIS	—	Chassis ground
18	Logic H	O	Pulled up to +5V through 3.9 K Ω resistor.
16,33 19-30	GND	—	Signal ground.
15,34	NC	—	Not connected.

* The I/O column indicates the direction of the signal as viewed from the printer.

The busy signal is active (HIGH) under the following conditions:

- During data reception(See Figure 1-6)
- When the input buffer is full
- When the-INIT input signal is active (low level)
- During the hardware initialization
- When the-ERROR or PE signal is active
- During the self-test mode
- During the default setting mode

The -ERROR signal is active(LOW) under the following conditions:

- When a paper-out error occurs
- When a no ink cartridge error occurs
- When a fatal error occurs

The PE signal is active (HIGH) under the following conditions:

- When a paper-out error occurs

1.3.2 Parallel Interface (Reverse channel)

Transmission mode	IEEE-1284 nibble mode
Adapatable connector	57-30360 (Amphenol) or equivalent
Snynchronization	Refer to the IEEE-1284 specification
Handshaking	Refer to the IEEE-1284 specification
Signal level	TTL-compatible (IEEE-1284 level 1 device)
Data transmission timing	Refer to the IEEE-1284 specificatin
Extensibility request	The printer responds to the extensibility request in the affirmative, when the request is 00H or 04H, which mean; 00H: Request nibble mode of reverse channel transfer 04H: Request device ID in nibble mode of reverse channel transfer
Device ID	Standardcolor version [00H] [3BH].....MFG: EPSON, CMD: ESCPL2-00 MDL: Stylus[SP] COLOR[SP]200, CLS: Printer Standard monochrome version [00H] [35H].....MFG:EPSON, CMD: ESCPL2-00 MDL:Stylus [SP]200, CLS: Printer

Table1-11. Pin Assignment for Reverse channel

Pin No.	Signal Name	I/O*	Description
1	HostClk	I	Host clock signal
2-9	DATA 1-8	I	Parallel Input data to the printer. bit 0:LSB bit 7:MSB
10	PtrClk	O	Printer clock signal.
11	PtrBusy / DataBit-3,7	O	Printer busy signal and reverse channel transfer data bit 3 or 7.
12	AckDataReq / DataBit-2,6	O	Acknowledge data request signal and reverse channel transfer data bit 2 or 6.
13	Xflag / DataBit-1,5	O	X-flag signal and reverse channel transfer data bit 1 or 5.
14	HostBusy	I	Host busy signal
31	-INIT	I	Not used
32	-Data Avail / DataBit-0,4	O	Data available signal and reverse channel transfer data bit 0 or 4.
36	1284-Active	I	1284 active signal.
18	Logic-H	O	This line is pulled up to +5 V through 3.9 K Ω resistor.
35	+5V	O	This line is pulled up to +5V through 1.0 K Ω resistor.
17	Chassis	—	Chassis GND.
16,33 19-30	GND	—	Signal ground.
15,34	NC	—	Not connected.

* In/Out refers to the direction of signal flow from the printer's point of view.

1.4 OPERATIONS

This section describes the basic operations of the printer.

1.4.1 Control Panel

The control panel for this printer has 2 non-lock-type push buttons, and 3 LED indicators for easy operation of the various printer functions.

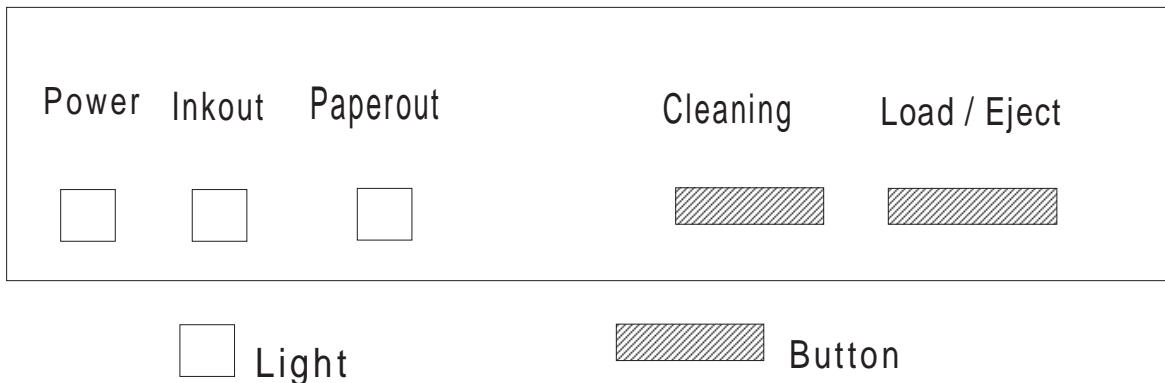

Figure1-7. Control Panel Appearance

1.4.2 Panel Operation and Built-in Function

You can activate the following modes by doing the procedure in table 1-11 and 1-12.

Table 1-12. Panel Operation

Button	Operations	+
^	Single Button Operations	+
^	Pressed and released	Held down 3 seconds
Cleaning	Cleaning head	No Function
Load/Eject	Load/Eject Exits from Ink Cartridge changing mode	Enters to Ink Cartridge changing mode

Table 1-13. Built-in Functions on the Panel

Button		Function
1'st switch Switch pushed with power on and release	2'nd switch Switch pushed within 3 seconds after power on	^
Cleaning	_____	Self test
Load/Eject + Cleaning	_____	Default Setting
Cleaning	Load /Eject	Data dump
Load/Eject	_____	Demonstration
Load/Eject + Cleaning	Load/Eject	Default Setting (without the sheets)
Load/Eject + Cleaning	Load/Eject *Hold down both buttons over 10 seconds until Ink Out and Paper Out light blink	Clear EEPROM
Load/Eject	Cleaning	Non-smear printing
Load/Eject + Cleaning	Load/Eject + Cleaning *Hold down both buttons over 10 seconds until Ink Out and Paper Out light blink	Clear user-setting on EEPROM
Other combinations	Other combinations	Not available

Table 1-14. Button Operations in Default Setting Mode

Button	Function
Load/Eject	Move through each menu
Cleaning	Select

Table 1-15. Error Indications

Printer Status	Indicators		+
^	Power	Inkout	Paperout
Ink low (printable)	On	Blinks	---
Ink out (unprintable)	On	On	---
Paper out	On	---	On
Paper Jam	On	---	Blinks
Replacing head/ink or During ink sequence	Blinks	---	---
No cartridge	On	On	---
No head	On	Blink (rapidly)	---
Carriage control error or Fatal Error	Blinks	On	On
Maintenance request	Blinks	Blinks	Blinks

1.4.3 Default Settings

The printer can save some printer setting parameters that define its functions at initialization. You can change these parameters using the printer's default setting mode.

1.4.3.1 Default Setting Items

You can use default setting mode to change settings listed in the table below. Activate default-setting mode by holding down the Load/Eject and Cleaning buttons while turning on the printer.

Table 1-16. Default Setting Items

Item	Selections		+
Character Tables	Standard Version		+
^	Italic USA Italic France Italic Germany Italic UK	Italic Italy Italic Spain PC437 PC850	PC865 PC861 BRASCII Abicomp
^	Italic Denmark Italic Sweden	PC860 PC863	^
^	NLSP Version		+
^	Italic USA Italic France Italic Germany Italic UK Italic Denmark Italic Sweden Italic Italy Italic Spain	PC437 PC850 PC853 PC857 PC437 Greek PC855 PC866 PC852	PC869 ISO 8859-7 ISO Latin 1T MAZOWIA Code MJK Bulgaria
Typestyles	Roman Sans Serif Courier Roman T (PS) Sans Serif H (PS)		+
Character Pitches	10 CPI (10 CPI, Condensed off) 12 CPI (12 CPI, Condensed off) 15 CPI (15 CPI, Condensed off) 17.1 CPI (10 CPI, Condensed on) 20 CP I(12 CPI, Condensed on) Proportional (PS, Condensed off)		+
Print Direction	Auto Bidirectional Uni-directional		+
Network I/F Mode	Off (Usual environment) On (Network environment)		+

Table 1-17. Default Setting Items (Continued)

Item	Contents
Auto line feed	<u>Off</u> On
Loading position	<u>8.5 mm</u> 3 mm
Thick paper	<u>Envelopes</u> Index card (portrait)

Note: The underlined value is the factory setting.

1.4.3.2 Changing the Default Settings

User is requested to operate 2 buttons watching 3 lights on the control panel. The lights turn on and off, and blink in one or the patterns described in the guidance sheets (language selection sheet and printer setting sheet) which are printed out at first in the setting mode. Please refer these sheets for the feature and character selection.

This setting modes uses 3 types of menu as follows;

Language menu: list of the languages to be used for the printer setting sheet

Main menu : list of items to be set (ex."CG table","Auto line feed")

Submenus : list of value/setting of the each item (ex."PC437", "ON")

1. Hold down the Load/Eject + Cleaning button and turn on the printer. The printer outputs a sheet that describes how to select the language used to print messages.
2. Power, InkOut and PaperOut LED indicate the top item(English) on "Language Menu". You can select a language by pressing the Cleaning button.(See Table 1-16.)

Table 1-18 Language Selection

	Power	InkOut	PaperOut
English	On	Off	Off
Français	Off	On	Off
Deutsch	On	On	Off
Italiano	Off	Off	On
Español	On	Off	On

3. Press Load/Eject button, the setting sheet is printed out in the language. This selection of language is not stored.
4. Power, InkOut and PaperOut indicate the top item on "main menu". You can select menu by the Cleaning button.
5. Press Load/Eject button, then printer changes the indication to the "submenu" of the selected item.
6. Power, InkOut and PaperOut indicate the current setting/value on the submenu. You can select setting/value by the Cleaning button.
7. Press Load/Eject button, then printer memorize the last setting/value and changes its indication to the main menu.(back to 2)

The other items can be changed in the same manner.

* In case the setting mode is activated with "without the sheets" option, the sequence 1 and 2 are going to be skipped.

1.4.4 Error Conditions

The printer can detect various errors and indicate them with LEDs. Refer to Table 1-14.

1.4.5 Printer Initialization

There are three initialization methods: power-on initialization, software initialization and operator initialization.

1.4.5.1 Power-On Initialization

This initialization of this level is activated by power-on or cold-reset command(remote RS command).

This initialization is:

- to initialize the printer mechanism.
- to execute Operator initialization.

1.4.5.2 Software Initialization

This initialization of this level is activated by the control code ESC @. This initialization is:

- -to clear the unprinted data.
- -to make the printer's setting defaults.

1.4.5.3 Operator Initialization

The initialization of this level is activated by-INIT signal (negative pulse), reset operation through panel or head replacement between monochrome and color.

- - to clear all data in the print buffer
- to cancel the download character definition.
- to make the printer stand-by state, if no errors occur.
- to execute Software initialization.

1.5 MAIN COMPONENTS

The main components of the Stylus Color IIs are:

- ❑ Printer mechanism (M-4C11)
- ❑ Main control board (C199 MAIN Board)
- ❑ Power supply unit (C160 PSB/PSE Board)
- ❑ Control panel board (C160 I/F Board)
- ❑ Housing

1.5.1 Main Control Board (C199 MAIN Board)

The main control board (C199 MAIN Board) consists of an M37721S2BP 16-bit CPU. The E05B32 gate array operates with 25MHz clock speed and controls various memories. The CR motor and PF motor are controlled directly by the CPU.

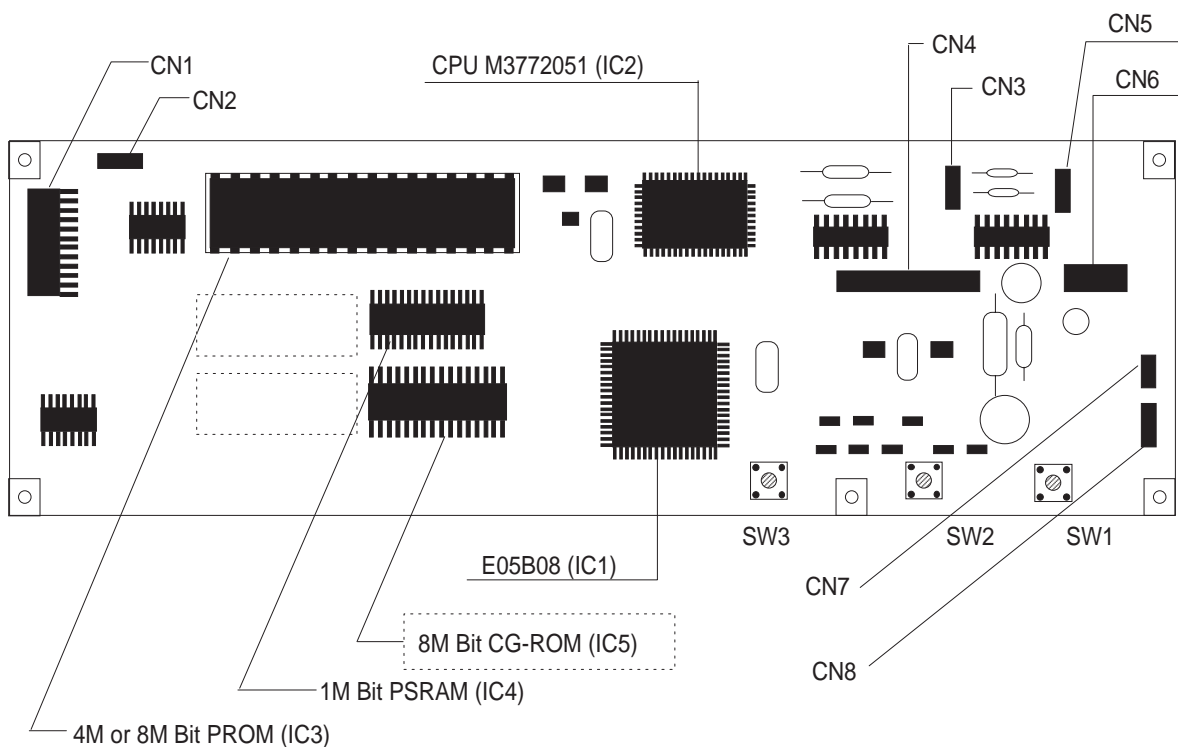

Figure 1-8. C199 Main Control Board Component Layout

1.5..2 Power Supply Board (C160 PSB/PSE Board)

The power supply board (C160 PSB/PSE Board) consists of an RCC switching regulator circuit. This board does not have a power switch connected to the secondary circuit like the Stylus Color series. Thus, if the printer is turned off, it cannot continue to operate in order to perform the head capping operation.

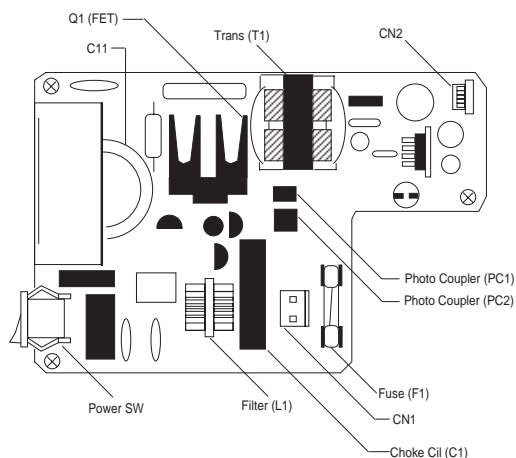

Figure 1-9. C160 PSB/PSE Board Component

1.5.3 Interface Board (C160 I/F Board)

There is an exclusive interface board to receive/transmit print data between the host computer and printer.

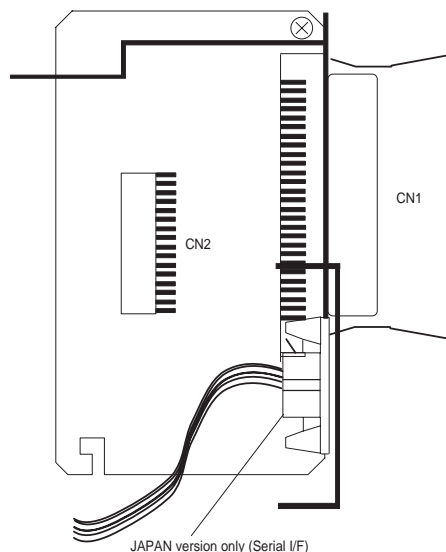

Figure1-10. C160 I/F Board Component Layout

1.5.4 Printer Mechanism (M-4C11)

The M-4C10 printer mechanism is equipped with a replaceable 64-nozzle black printhead and 60-nozzle color (CMY) printhead, and it can print at a high resolution (720 dpi) using the special coated paper.

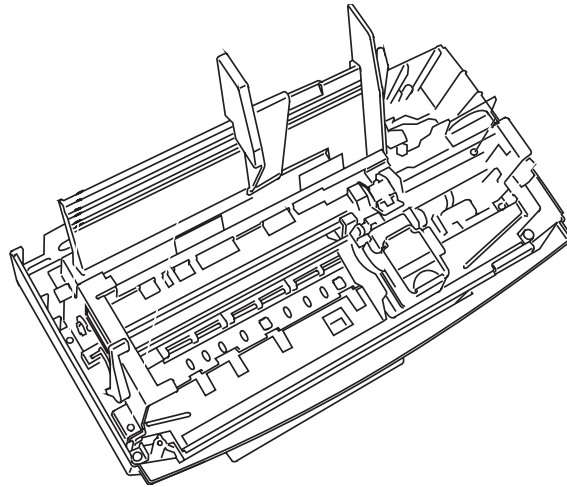

Figure 1-11.M-4C11 Printer Mechanism

1.5.5 Housing

The Epson Stylus Color 200/Epson Stylus 200 housing consists of the printer cover, upper case, and lower case. Attached to the housing are the front paper support and ejected paper support with paper separator.

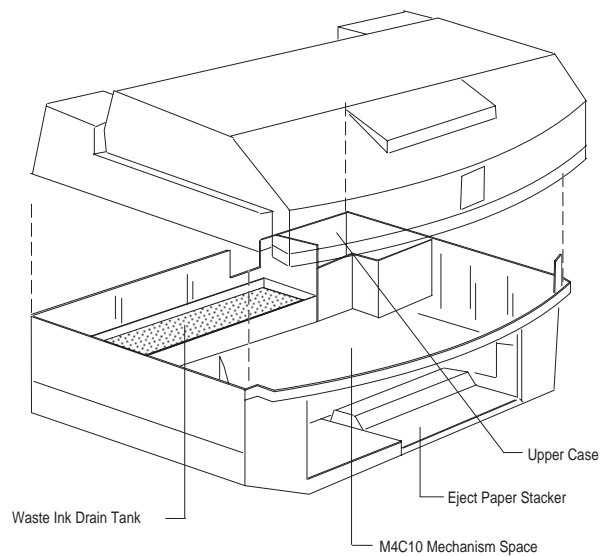

Figure 1-12. Housing Component Layout

Chapter 2 Operating Principles

Table of Contents

2.1 OVERVIEW	2-1
---------------------	------------

2.1.1 C199 Main Board	2-1
2.1.1.1 Carriage Motor Driver Circuit	2-2

List of Figures

Figure 2-1. C199 Main Board	2-1
Figure 2-2. Carriage Motor Drive Circuit Block Diagram	2-2

List of Tables

Table 2-1. Carriage Motor Drive Sequence	2-2
Table 2-2. Connection between the reference and the output signal	2-3

2.1 OVERVIEW

Since the printer mechanism of the EPSON Stylus COLOR 200 is the same as for the EPSON Stylus COLOR IIs, this section only describes the differences in electrical circuitry.

2.1.1 C199 MAIN BOARD

The main control board for the EPSON Stylus COLOR 200 is the C199 MAIN board. The major difference between the electrical circuitry of the C199 MAIN board and C160 MAIN board (used in the EPSON Stylus COLOR IIs) is that the new board incorporates a new CR drive circuit. The figure below shows a block diagram of the C199 MAIN board circuitry.

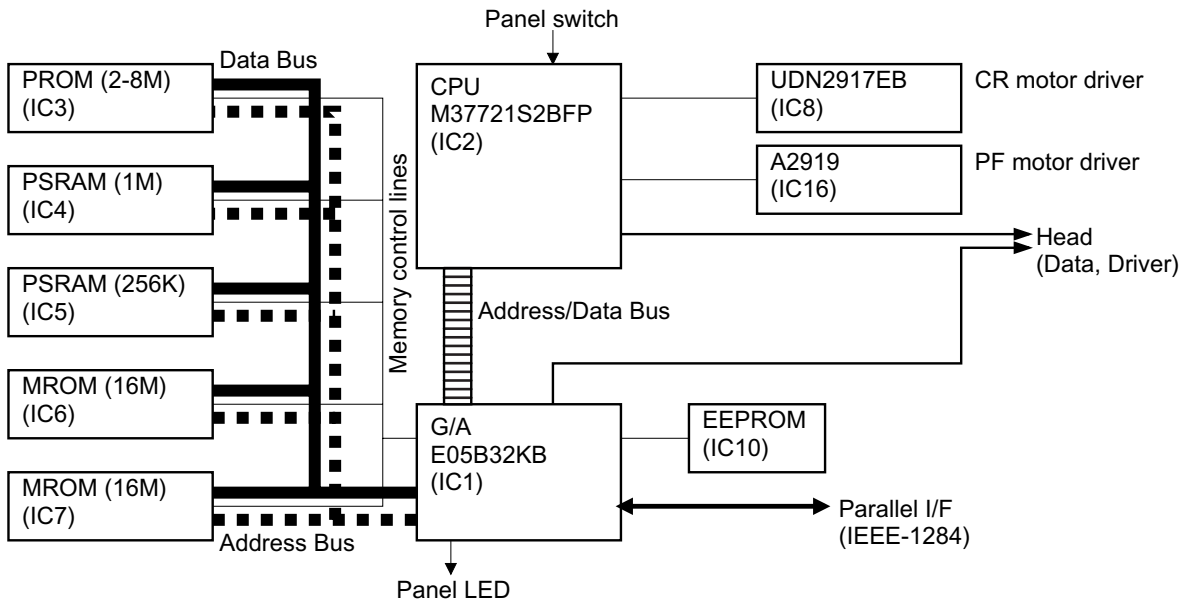

Figure 2-1. C199 MAIN Board Block Diagram

2.1.1.1 Carriage Motor Driver Circuit

Carriage motor driver IC UDN2917EB (IC8) outputs a constant current to drive the carriage motor. CPU M3772152BFP (IC2) determines the motor phase and speed, and then sends a signal to the UDN2917EB carriage motor driver IC (IC8) via a 4-bit signal transmission line. The carriage motor is controlled by a 2W1-2 phase drive method. The figure below shows the carriage motor driver circuit block.

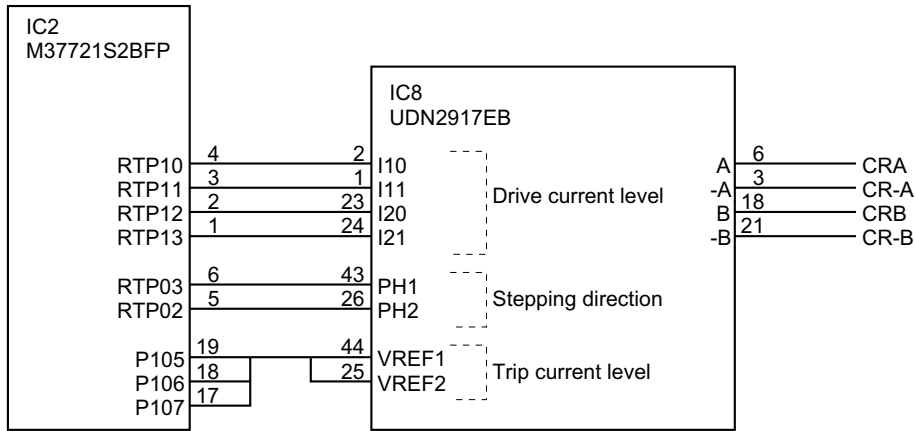

Figure 2-2. Carriage Motor Drive Circuit Block Diagram

Motor driver IC UDN2917EB controls the motor stepping direction and drive current with a combination of six signals supplied from the CPU. PH1 and PH2 signals control the current flow direction to determine the motor stepping position; and the I10, I11 and I20, I21 signals determine the drive current supplied to each motor drive coil. Table 2-1 lists the combinations of these signals used for the 2W1-2 phase drive control.

Table 2-1. Carriage Motor Drive Sequences

Sequence	Phase A				Phase B			+
^	RTP03	RTP10	RTP11	Current Duty	RTP02	RTP12	RTP13	Current Duty
^	PH1	I11	I10		PH2	I21	I22	^
0	0	0	0	-1	0	1	1	0
1	0	0	0	-1	0	1	0	-1/3
2	0	0	1	-2/3	0	0	1	-2/3
3	0	1	0	-1/3	0	0	0	-1
4	1	1	1	0	0	0	0	-1
5	1	1	0	+1/3	0	0	0	-1
6	1	0	1	+2/3	0	0	1	-2/3
7	1	0	0	+1	0	1	0	-1/3
8	1	0	0	+1	0	1	1	0
9	1	0	0	+1	1	1	0	+1/3
10	1	0	1	+2/3	1	0	1	+2/3
11	1	1	0	+1/3	1	0	0	+1
12	0	1	1	0	1	0	0	+1
13	0	1	0	-1/3	1	0	0	+1
14	0	0	1	-2/3	1	0	1	+2/3
15	0	0	0	-1	1	1	0	+1/3

In the Table 2-1, if the control sequence is executed in incremental order, the carriage motor rotates clockwise (CW). (The CR moves from 1st column to 80th column.)

Signals output from ports P105, P106, and P107 of the CPU determine the reference trip current level used by the motor driver IC for drive current control. Table 2-2 lists the connection of the output signals and the reference trip current levels.

Table 2-2. Connection between References and Output Signals

Reference (Trip Current)	P105	P106	P107	Duty Change
601 mA	OFF	OFF	OFF	1, 2/3, 1/3, 0
481 mA	ON	OFF	OFF	As above
444 mA	OFF	ON	OFF	As above
403 mA	OFF	OFF	ON	As above
375 mA	ON	ON	OFF	As above
345 mA	ON	OFF	ON	As above
326 mA	OFF	ON	ON	As above
110 mA	OFF	ON	ON	Fixed to 1/3

Chapter 3 Disassembly and Assembly

Table of Contents

3.1 OVERVIEW	3-1
3.1.1 Precautions for Disassembling the Printer	3-1
3.2 DISASSEMBLY AND ASSEMBLY	3-1
3.2.1 Upper Case Removal	3-2
3.2.2 C199 Main Board Removal	3-3
3.2.3 C160 I/F Board Removal	3-4
3.2.4 C160 PSB/PSE Board Removal	3-5
3.2.5 M-4C11 Printer Mechanism Removal	3-6
3.2.6 Printer Mechanism Disassembly	3-7
3.2.6.1 Carriage Unit Removal	3-7
3.2.6.2 ASF Unit Removal	3-9
3.2.6.3 PE Sensor Removal	3-9
3.2.6.4 Pick Up Roller Unit Removal	3-10
3.2.6.5 Carriage Home Position Sensor Removal	3-10
3.2.6.6 Paper Feed Roller Unit Removal	3-11
3.2.6.7 Carriage Motor Removal	3-11
3.2.6.8 Head Cleaner Replacement	3-12
3.2.6.9 Cap Unit Removal	3-13
3.2.6.10 Paper Feed Motor Removal	3-14

LIST OF FIGURES

Figure 3-1. Upper Case Removal	3-2
Figure 3-2. C199 Main Board Removal	3-3
Figure 3-3. ASF Sensor Removal.	3-3
Figure 3-4. Board Frame and Metal Stay Removal.	3-4
Figure 3-5. C160 I/F Board Removal	3-4
Figure 3-6. C160 PSB/PSE Board Removal	3-5
Figure 3-7. Printer Mechanism Removal.	3-6
Figure 3-8. PG Lever and Tension Coil Removal	3-7
Figure 3-9. Parallelism Adjust Lever Removal	3-8
Figure 3-10. Carriage Unit Removal.	3-8
Figure 3-11. ASF Unit Removal	3-9
Figure 3-12. PE Sensor Removal	3-9
Figure 3-13. Pick Up Roller Unit Removal.	3-10
Figure 3-14. Carriage Home Position Sensor	3-10
Figure 3-15. Paper Feed Roller Unit Removal	3-11
Figure 3-16. Carriage Motor Removal	3-11
Figure 3-17. Head Cleaner Replacement.	3-12
Figure 3-18. Pump Unit Removal	3-13
Figure 3-19. Pump Unit Releasing	3-13
Figure 3-20. Pin Position	3-14
Figure 3-21. Paper Feed Motor Removal.	3-14

3.1 OVERVIEW

This section describes procedures for disassembling the main components of the printer. Unless otherwise specified, disassembled units or components can be reassembled by reversing the disassembly procedure. Therefore, no assembly procedures are included. Precautions for any disassembly or assembly procedure are described under the heading "Disassembly/Assembly Points." Adjustments required after assembling the unit are described under the heading "Required Adjustments."

3.1.1 Precautions for Disassembling the Printer

See the precautions below when disassembling the printer.

WARNING

- Disconnect the power cable before disassembling or assembling the printer.*
- Wear goggles to protect your eyes from ink. If ink gets in your eye, flush it with fresh water and see a doctor immediately.*
- If ink comes into contact with your skin, wash it off with soap and water. If irritation occurs, contact a physician.*

CAUTION

- Never remove the ink cartridge from the carriage unless manual instructions specify to do so.*
- When transporting the printer after installing the ink cartridge, be sure to pack the printer for transportation without removing the ink cartridge.*
- Use only recommended tools for disassembling, assembling, or adjusting the printer.*
- Use only O-11 oil when lubricating the carriage guide shaft.*
- Apply lubricants and adhesives as specified. (See Chapter 6.)*
- Make specified adjustments when you disassemble the printer. (See Chapter 4.)*

3.2 DISASSEMBLY AND ASSEMBLY

This section consists of the subheads shown in the diagram below. See the exploded view of the printer in the Appendix, if necessary.

WARNING

Follow the precautions in Section 3.1.1 when disassembling the printer.

This section consists of the subheads shown in the diagram(next page).

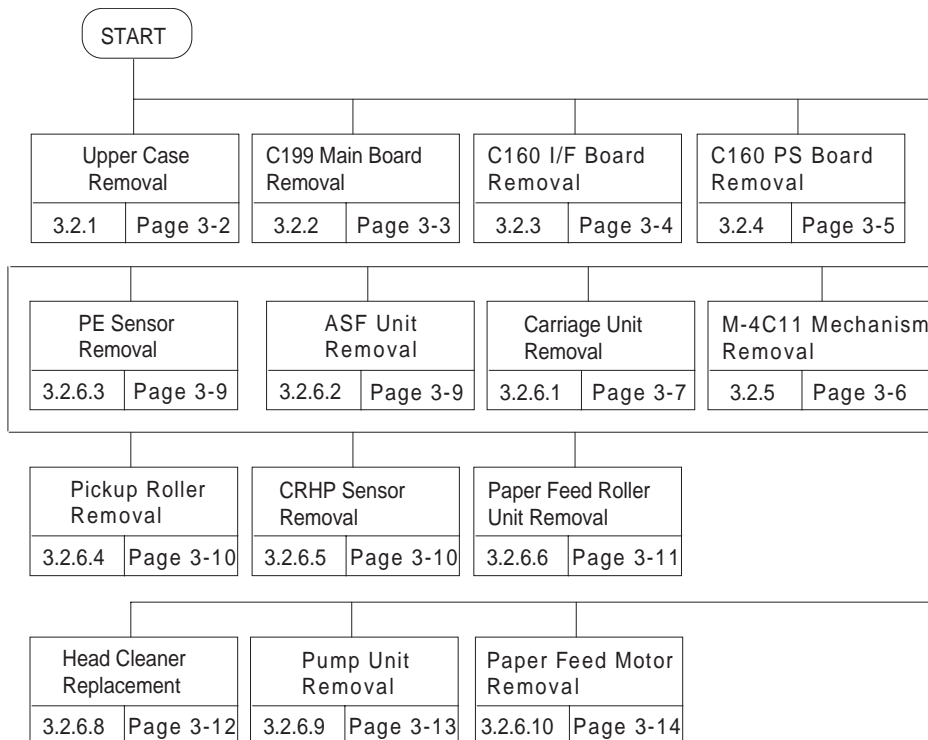

3.2.1 Upper Case Removal

1. Remove the sheet guide from main unit. Then remove 2 CBB (M4 × 11) screws securing the upper case to the bottom case.
2. Open the front cover; then remove 2 CBB (M4 × 11) screws securing the upper case to the bottom case.
3. Remove 1 small screw securing the ASF knob to the lever.
4. Remove the upper case by lifting the front side.

DISASSEMBLY/ASSEMBLY POINT

When you move the carriage unit manually to remove 1 screw(), push it once toward the right, and move to the left side .*

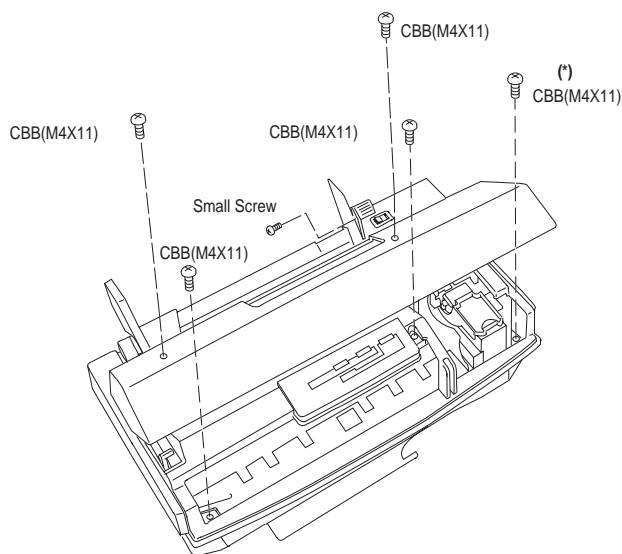

Figure 3-1. Upper Case Removal

3.2.2 C199 MAIN Control Board and ASF Sensor Removal

1. Remove the upper case (see Section 3.2.1).
2. Remove 4CBB (M3×6) screws attaching the shield frame to the C160 MAIN Board.
3. Remove 7 connectors (CN1, CN8, CN7, CN4, CN3, CN5, CN6) on the main board. (Push CN6 down to release cable on main board.) Then remove the C199 Main Control Board.
4. Remove a CBB (M3x6) screw fixing a ASF Sensor holder to printer mechanism.



When you replace the C199 MAIN Board, reset the EEPROM and perform the required adjustments. (See Chapter 4.)

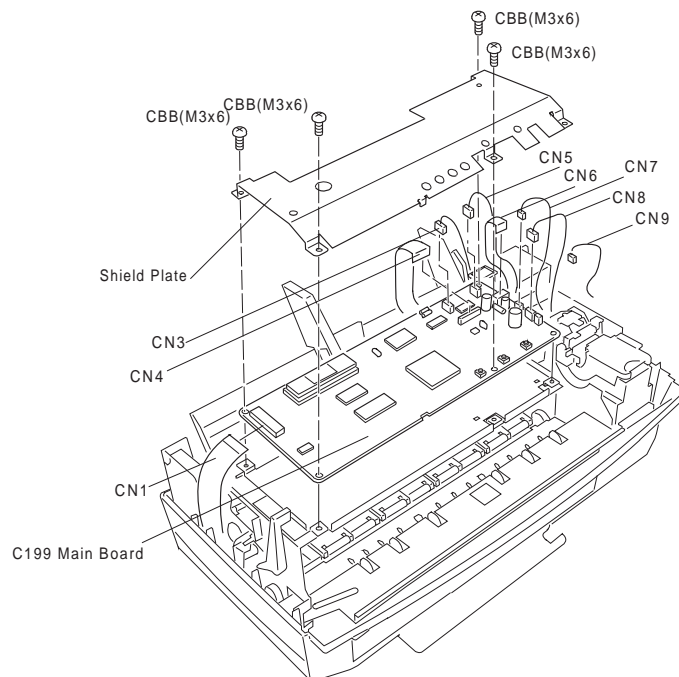

Figure 3-2. C199 Main Board Removal

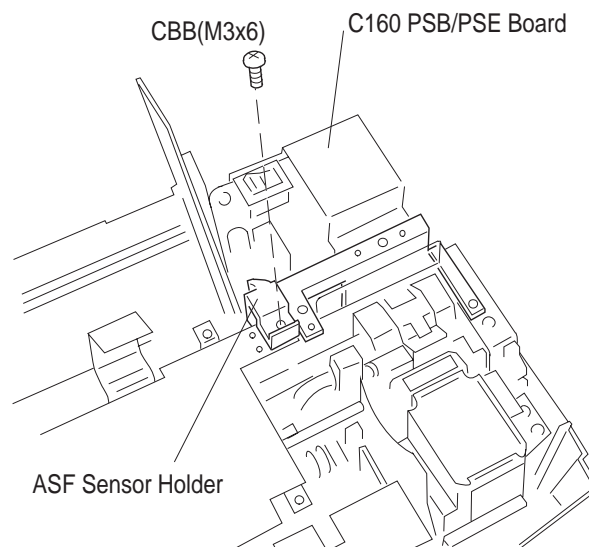

Figure 3-3. ASF Sensor Removal

5. Remove 3 CPS (M3×6) screws fixing the board frame to the mechanism and 1 CPS (M3×6) screw fixing the metal stay between the board frame and the right side frame. Then remove the metal stay.
6. Remove 2 CPS (M3×6) screws fixing the transparency plate, then remove it.
7. Release the 3 hooks securing the FFC cable to the board frame then remove the board frame.

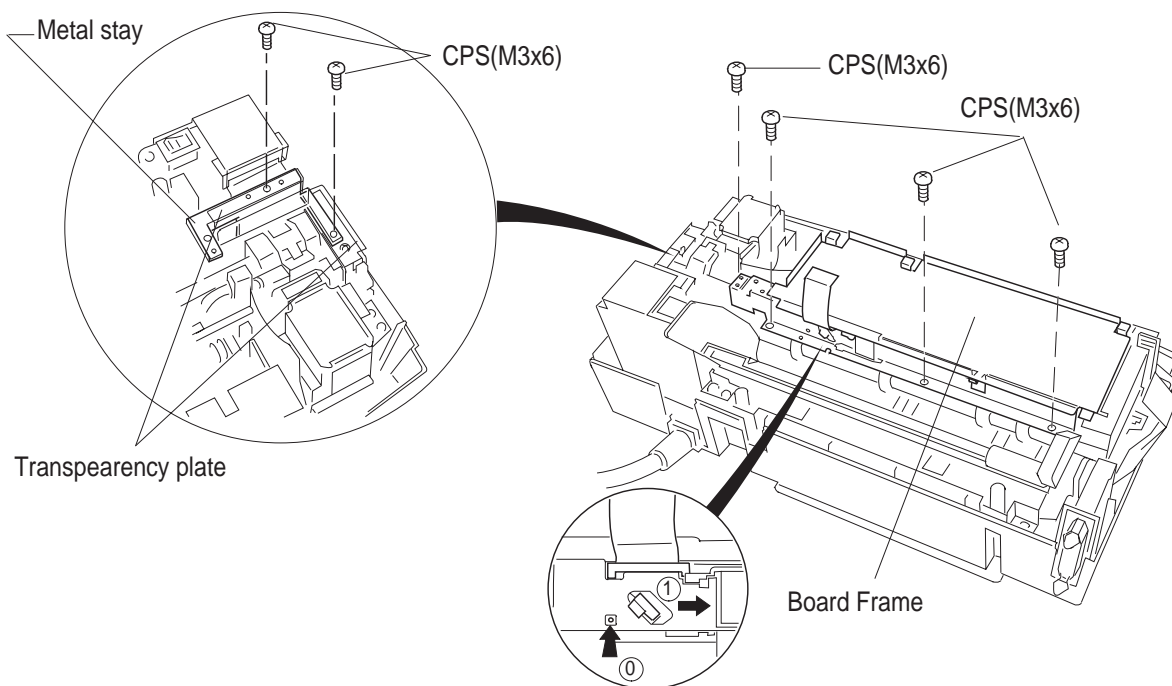

Figure 3-4. Board Frame and Metal Stay Removal

3.2.3 C160 I/F Board Removal

1. Remove the upper case (see Section 3.2.1).
2. Remove 2 CPS (M3×6) screws and 1 CBB (M3×10) securing the C160 I/F Board to the mechanism and bottom case.
3. Disconnect CN1 on this board; then remove it by lifting it up.

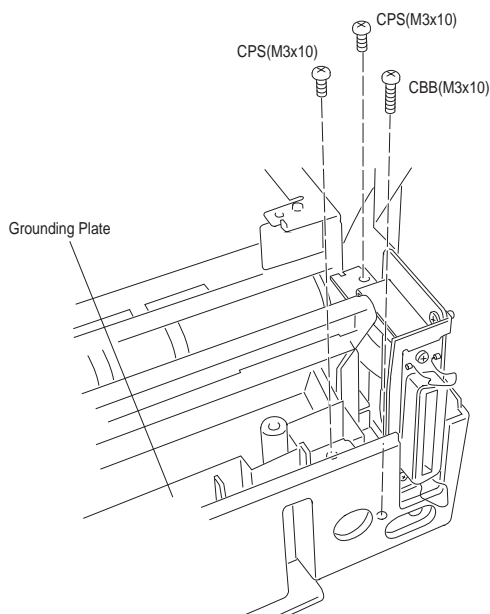

Figure 3-5. C160 I/F Board Removal

3.2.4 C160 PSB/PSE Board Removal

1. Remove the upper case (see Section 3.2.1).
2. Remove 1 CBB (M3×10) screw securing the power supply board to the lower case, 1 CPS (M3×6) screw securing the board frame to the grounding plate, 1 CBB (M3×10) screw fixing the board frame and 1 big screw securing the board frame to the lower case via the grounding plate.

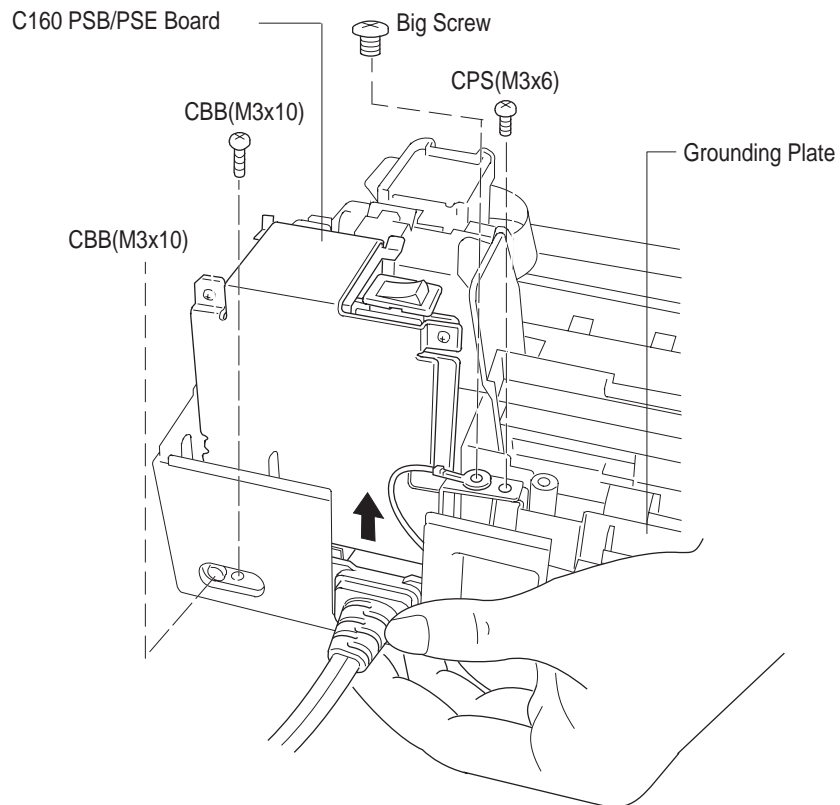

Figure 3-6. C160 PSB/PSE Board Removal

3.2.5 M-4C11 Printer Mechanism Removal

1. Remove the upper case (see Section 3.2.1).
2. Remove the C199 MAIN Board (see Section 3.2.2).
3. Remove the C160 I/F Board (see Section 3.2.3).
4. Remove the C160 power supply board (see Section 3.2.4).
5. Remove 4 CBB (M4x11) screws securing the printer mechanism to the lower case.



When you replace the printer mechanism, perform the required adjustments. (See Chapter 4.)

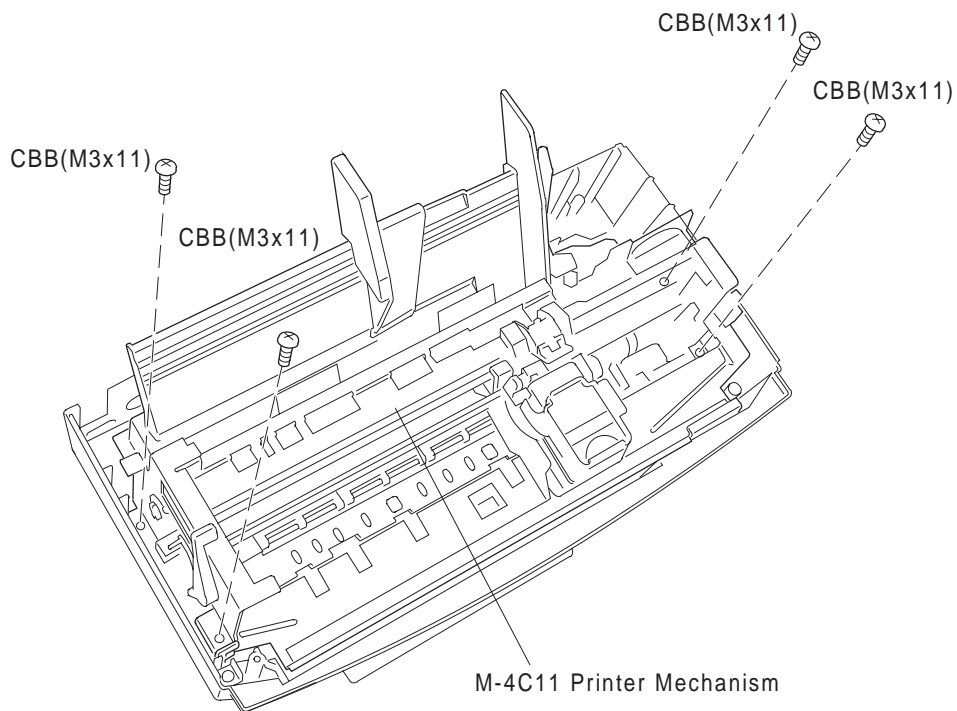

Figure 3-7. Printer Mechanism Removal

3.2.6 Printer Mechanism Disassembly

The procedures described in this section explain how to remove components within the printer mechanism.

3.2.6.1 Carriage Unit Removal

1. Remove the printer mechanism (see Section 3.2.6).
2. Remove the blue PG lever.
3. Remove the tension coil securing the parallelism bushing to the side frame.



Use only O-11 oil when lubricating the carriage guide shaft.

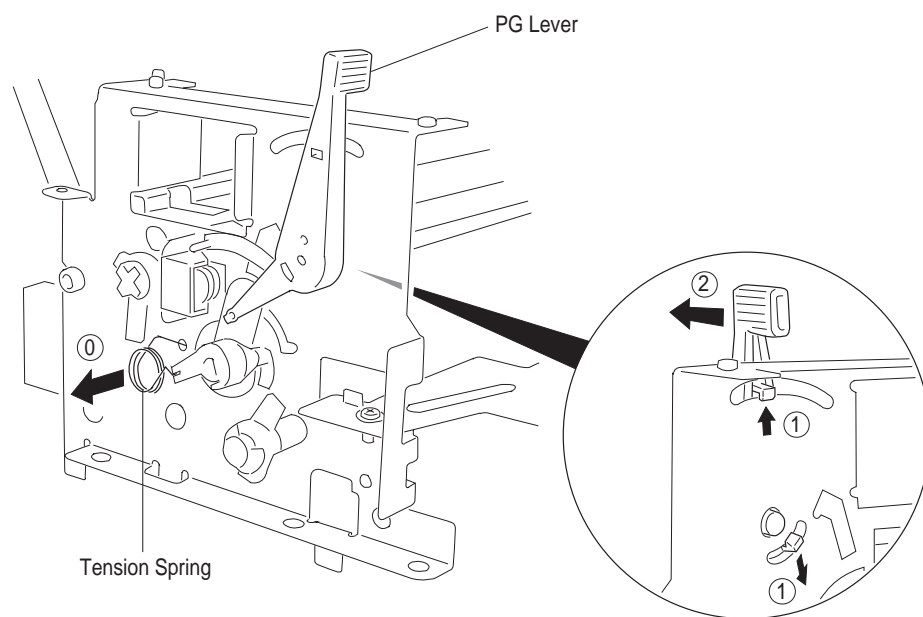

Figure 3-8. PG Lever and Tension Coil Removal

4. Remove the parallelism adjust lever by rotating it toward front while pulling the lever knob.

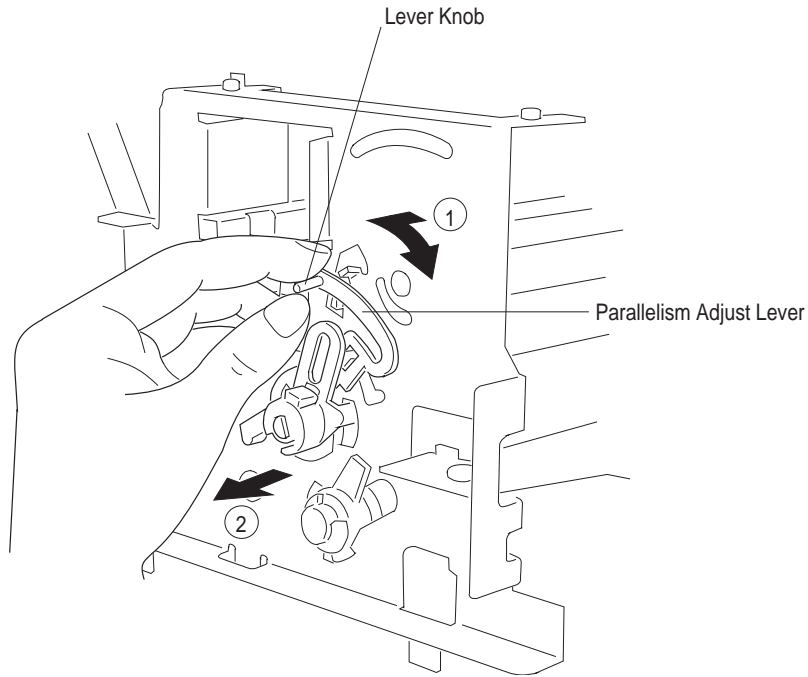

Figure 3-9. Parallelism Adjust Lever Removal

5. Remove the timing belt while pressing the pulley holder, then remove the carriage unit along with the carriage guide shaft.

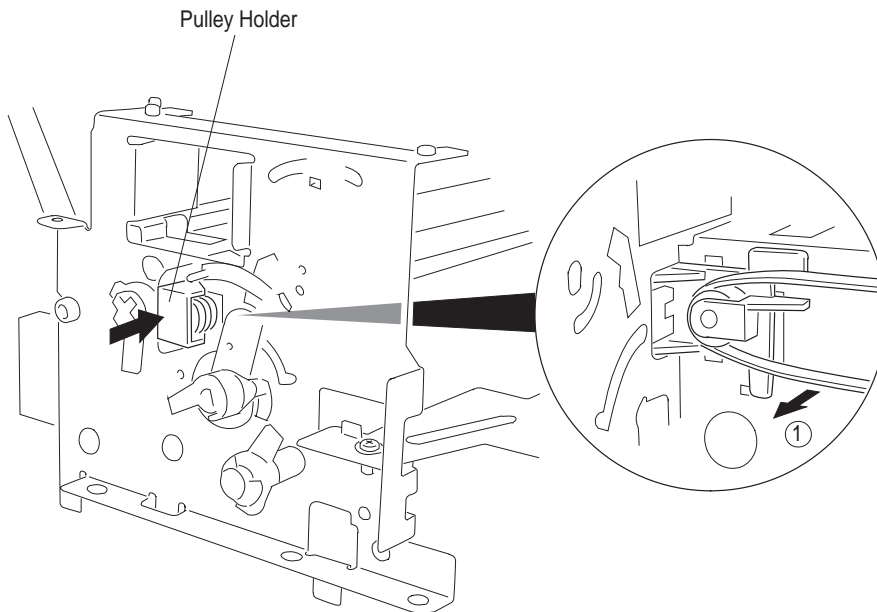

Figure 3-10. Carriage Unit Removal

3.2.6.2 ASF Unit Removal

1. Remove the printer mechanism (see Section 3.2.5).
2. Press down the tab on the left side; then pull the ASF unit toward you.
3. Press the tab on the right side; then remove the ASF unit.



When you remove the ASF, be extremely careful of the PE sensor. Pull the top of the ASF unit toward the front of the mechanism to clear the PE sensor.

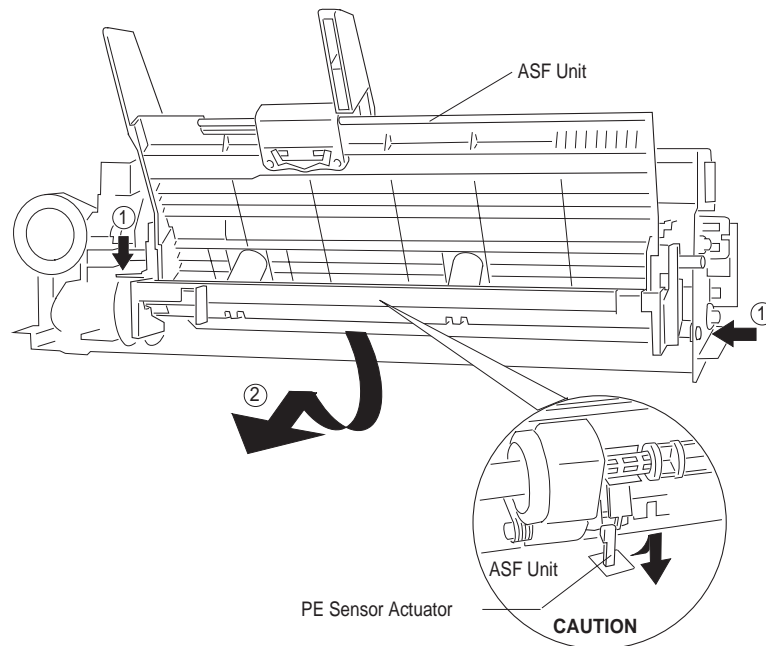

Figure 3-11. ASF Unit Removal

3.2.6.3 PE Sensor Removal

1. Remove the printer mechanism (see Section 3.2.5).
2. Remove the ASF unit (see Section 3.2.6.2).
3. Disconnect CN7 on the C199 MAIN Board, then remove the PE sensor.

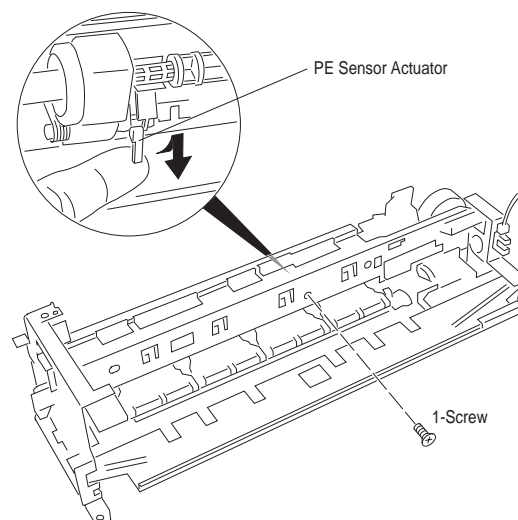

Figure 3-12. PE Sensor Removal

3.2.6.4 Pickup Roller Unit Removal

1. Remove the printer mechanism (see Section 3.2.5).
2. Remove the ASF unit (see Section 3.2.6.2).
3. Remove the PE sensor (see Section 3.2.6.3).
4. By rotating it, remove 1 shaft holder securing the roller shaft to the frame.
5. Remove the pickup roller unit, referring to the following illustration.

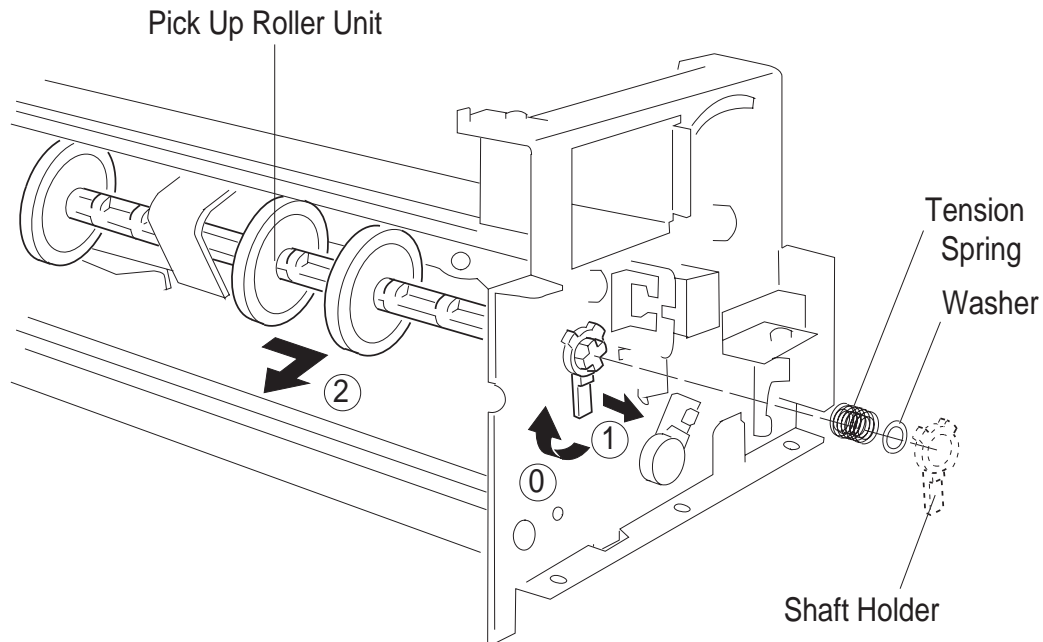

Figure 3-13. Pickup Roller Unit Removal

3.2.6.5 Carriage Home Position Sensor Removal

1. Remove the printer mechanism (see Section 3.2.5).
2. Disconnect the CN8 on the C199 MAIN Board.
3. Remove the 2 CPS (M3x6) screws securing the metal stay to the printer mechanism.

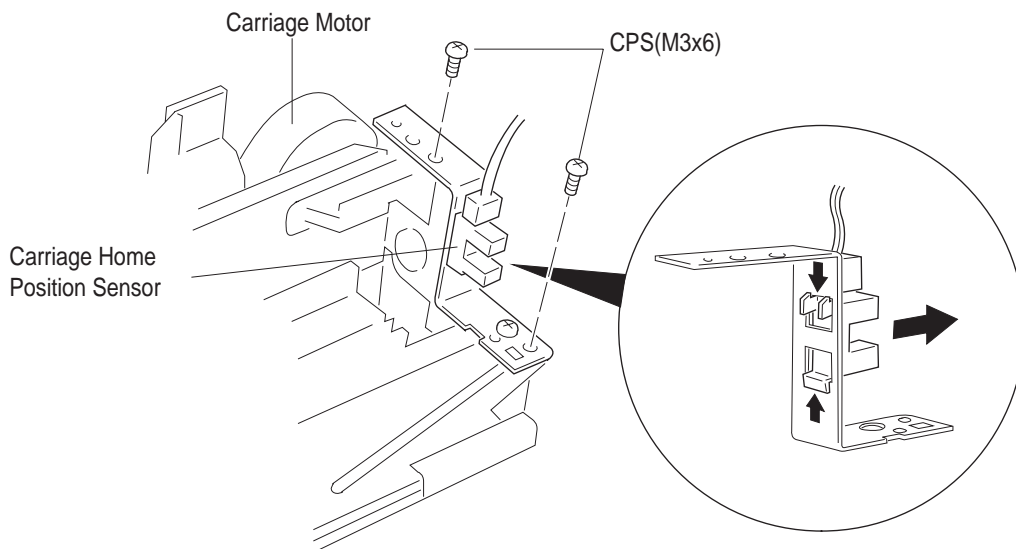

Figure 3-14. Carriage Home Position Sensor Removal

3.2.6.6 Paper Feed Roller Unit Removal

1. Remove the printer mechanism (see Section 3.2.5).
2. Remove the carriage unit (see Section 3.2.6.1).
3. Remove the carriage home position sensor (see Section 3.2.6.5).
4. Remove the tension spring holding the tension roller assembly to the sub frame.
5. Remove 2 CPS (M3x6) screws securing the front frame to the printer mechanism.
6. Remove the paper feed roller unit.

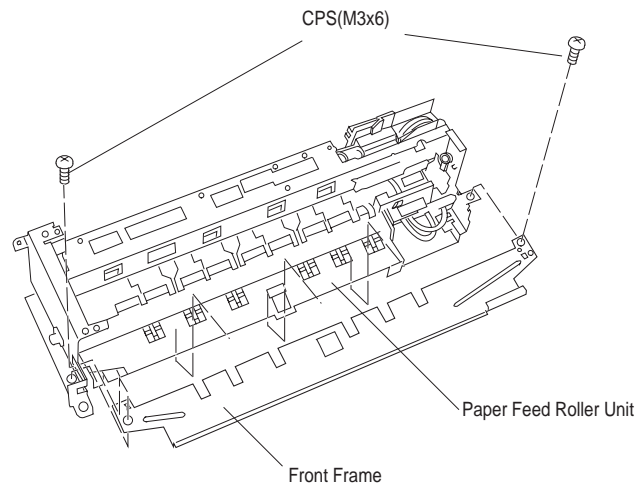

Figure 3-15. Paper Feed Roller Unit Removal

3.2.6.7 Carriage Motor Removal

1. Remove the printer mechanism (see Section 3.2.5).
2. Remove the carriage unit (see Section 3.2.6.1).
3. Remove the carriage (CR) motor.

Note: When you remove the CR motor, be sure to keep the washer on the CR motor gear.



When you remove or remount the CR motor, be careful of the post at both the top and bottom of the motor. If this post is broken, the motor will not seat correctly and can move during printing.

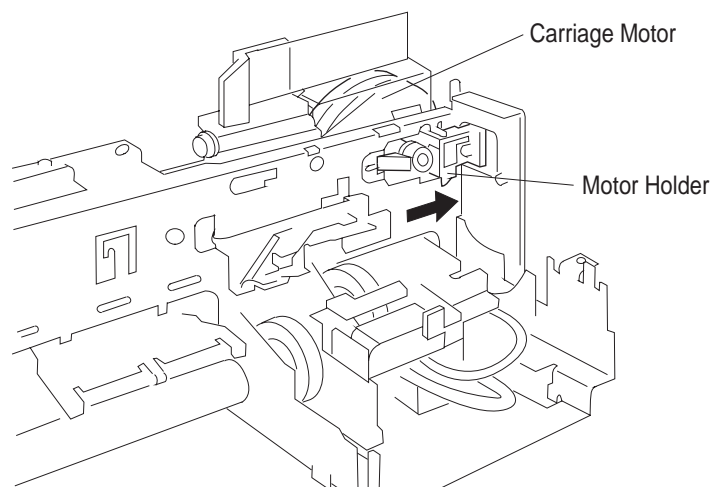

Figure 3-16. Carriage Motor Removal

3.2.6.8 Head Cleaner Replacement

1. Remove the printer mechanism (see Section 3.2.5).
2. Remove the front frame (see Section 3.2.6.6).
3. Use tweezers to unhook the head cleaner.

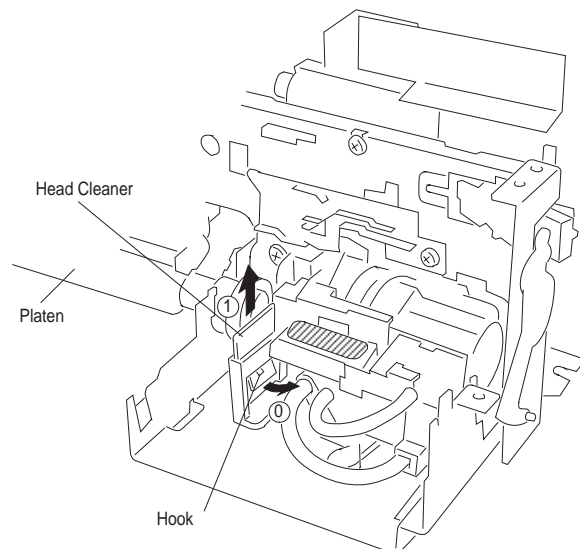

Figure 3-17. Head Cleaner Replacement



- Never touch the head cleaner with your bare hands.
- When attaching the head cleaner, wear gloves and use clean tweezers to handle it.

3.2.6.9 Cap Unit Removal

1. Remove the printer mechanism (see Section 3.2.5).
2. Remove the front frame (see Section 3.2.6.6).
3. Remove 1 CPS (M3x6) screw securing the cap unit to the lower frame.

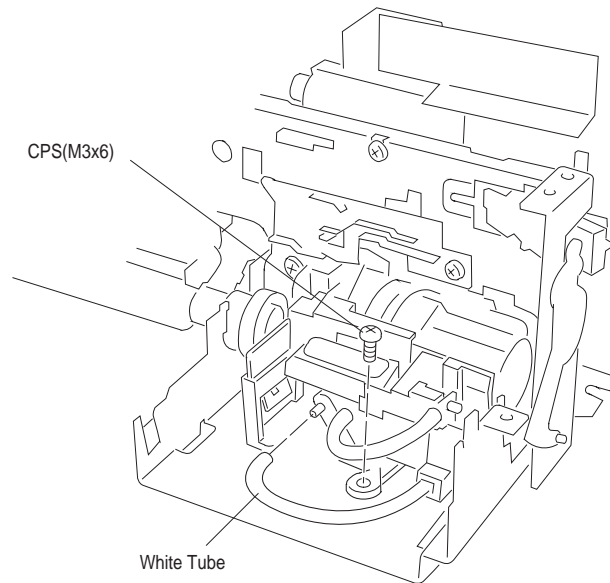

Figure 3-18. Pump Unit Removal

4. Remove 1 CPS (M3x6) screw securing the black holder to the frame
5. Remove the white tube connecting the cap unit to the pump unit. (Be careful an ink leak when you remove this ink tube.)
6. Remove 3 screws — 1 CPS (M3x6), 1 CPS (M3x12), and 1 CPS (M3x8) — securing the pump unit to the main frame.
7. Release a tension spring securing the paper pick up trigger holder to the pump mechanism.

Notes:

1. When you remove the pump unit, be sure to keep the washer, located behind the pump.
2. When you remove the pump unit, do not lose the pin in the pin holder.

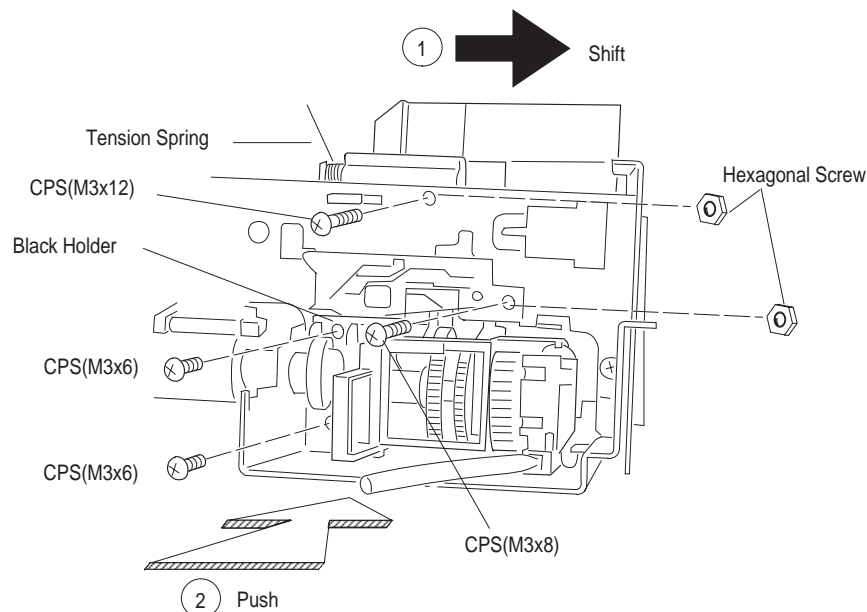

Figure 3-19. Pump Unit Releasing

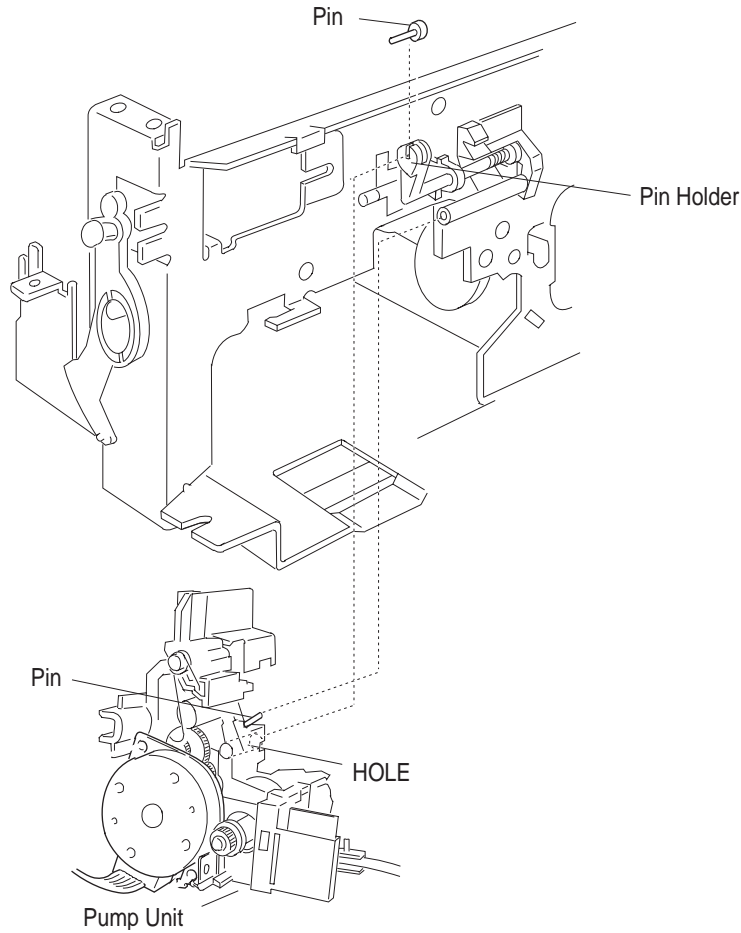

Figure 3-20. Pin Position

3.2.6.10 Paper Feed Motor Removal

1. Remove the printer mechanism (see Section 3.2.5).
2. Remove the pump unit. (see Section 3.2.6.9).
3. Remove the 2 CBB (M3x10) screws securing the paper feed motor to the motor frame.

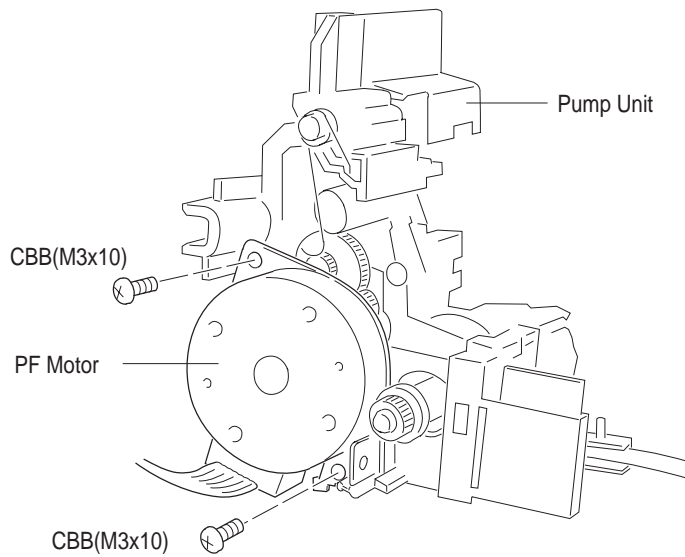

Figure 3-21. Paper Feed Motor Removal

Chapter 4 Adjustment

Table of Contents

4.1 OVERVIEW	4-1
4.1.1 Bi-D (Bidirectional Printing) Alignment Adjustment	4-2
4.1.2 Head Angle Adjustment	4-3
4.1.3 Zig-Zag Adjustment	4-3
4.1.4 Platen Gap Adjustment	4-4
4.1.5 EEPROM Reset Procedure	4-5

List of Figures

Figure 4-1. Bi-D Alignment	4-2
Figure 4-2. Angle Lever Operation	4-3
Figure 4-3. PG Lever Operation	4-4
Figure 4-4. Confirmation Method	4-7

List of Tables

Table 4-1. Required Adjustments	4-1
Table 4-2. Gap and Adjustment Direction	4-4
Table 4-3. EEPROM Operation	4-5

4.1 OVERVIEW

This section describes adjustments required when the printer is disassembled and assembled for repair.



□ After removing an ink cartridge, always install a new cartridge immediately.
During adjustments and testing, use cartridges designed exclusively for service :

Monochrome:1023206
CMY (Color):1029341

Table 4-1. Required Adjustments

Service Performed	Adjustment Needed
After replacing the M-4C11 printer mechanism.	Bi-D Alignment Adjustment (see 4.1.1)
After replacing the C199 MAIN board.	1. EEPROM Reset (see 4.1.5) 2. Bi-D Alignment Adjustment (see 4.1.1)
When vertical lines are not aligned. When a white line appears after the printer performs a single print pass.	1. Bi-D Alignment Adjustment (see 4.1.1) 2. Head Angle Adjustment (see 4.1.2)
After replacing or disassembling the carriage unit.	Platen Gap Adjustment (see 4.1.4)
When the printer indicates a Maintenance Error.	Maintenance Error Clear (see 4.1.5.4)
After replacing the waste ink pad.	Maintenance Error Clear (see 4.1.5.4)

4.1.1 Bi-D (Bidirectional Printing) Alignment Adjustment

The bidirectional alignment adjustment is required when the printer mechanism, main board, or printhead (or printhead board) is replaced. Performing this adjustment determines the compensation value needed to rectify any deviation in the print position. This deviation could be caused by the different print speeds, which are due to tolerances in the mechanical components, or to differences in print timing between odd-numbered lines and even-numbered lines in bidirectional printing. The printer stores the compensation data in the EEPROM on the C199 MAIN board and refers to this data when performing bidirectional printing.

Bidirectional Adjustment is Necessary

- After replacing the C199 MAIN board.
- After replacing the printer mechanism.
- After disassembling the printer mechanism (for example, to replace the carriage motor).
- After replacing the printhead.

Adjustment Procedure

1. Connect the printer to the PC, and load paper in the printer.
2. Run adjustment program CLR200.EXE on the PC. Then, follow the program instructions, and select the Bi-D alignment operation.
3. Choose the type of head currently installed in the printer. The printer prints a Bi-D pattern with the current value.
4. Refer to the printed alignment check pattern, and specify the compensation value.
 - To shift the even-numbered line to LEFT: Input (-) value.
 - To shift the odd-numbered line to RIGHT: Input (+) value.

Bi-D Mode : BLACK Head / Print-speed : 167 cps (Draft) / VALUE :

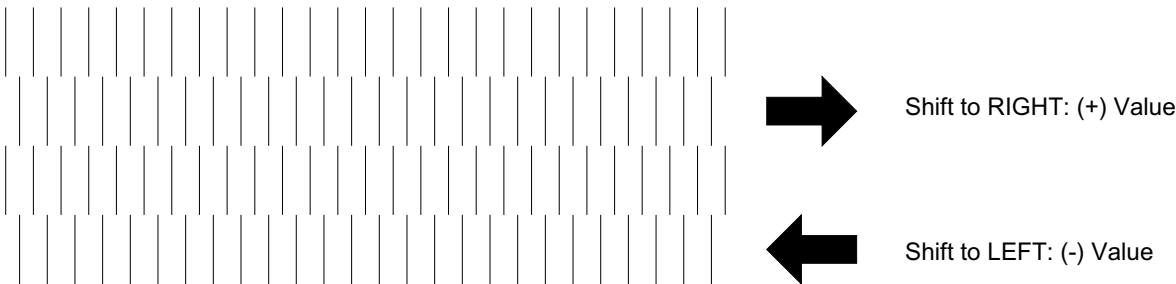

Figure 4-1. Bi-D Alignment

4.1.2 Head Angle Adjustment

The adjust lever on the carriage unit calibrates the printhead mounting position on the carriage unit. You must adjust the position of this lever properly to compensate for deviations in the carriage unit and the printhead.

Head Angle Adjustment is Required

- After replacing or disassembling the carriage unit.
- When a blank space (white line) is visible between the dotted lines printed by adjacent dots within single print pass.

Adjustment Procedure

1. Run adjustment program CLR200.EXE, and select **Head Angle Adjustment**. Then follow program instructions.
2. Check the pattern printed by the printer. If the alignment is not correct, as shown in the figure below, change the position of the adjust lever on the carriage unit.
 - To move the reference line UPWARD: Move the lever to the FRONT.
 - To move the reference line DOWNWARD: Move the lever to the REAR.

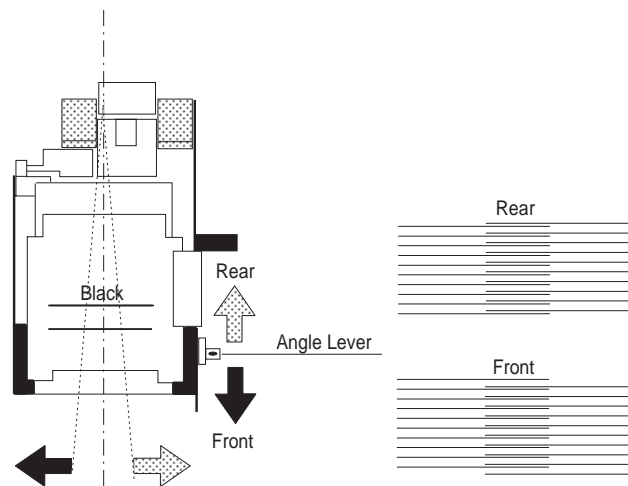

Figure 4-2. Angle Lever Operation

3. When the adjustment is complete, return to the program's main menu, and turn the printer off.

4.1.3 Zig-Zag Adjustment

If a vertical line (for example, the vertical strokes of the character "H") is jagged, adjust the deviation in the print timing control to align the printed dot properly on the paper.

1. Run the adjustment program CLR200.EXE, and select **Zig-Zag Adjustment**.
2. Check the printed pattern. If it is jagged, enter an appropriate adjustment value and confirm the pattern.
3. When the adjustment is complete, return to the main menu, and turn the printer off.

4.1.4 Platen Gap Adjustment

This adjustment is required after you have removed the carriage unit from the main unit or replaced the carriage unit. Adjust the distance between the printhead nose and the paper surface to 1.18 mm.

1. Remove the upper case, and place a thickness gauge (commercially available) on the paper guide plate at the adjustment position on the left side of the printer, as shown in the figure below:
2. Move the carriage unit manually onto the thickness gauge.

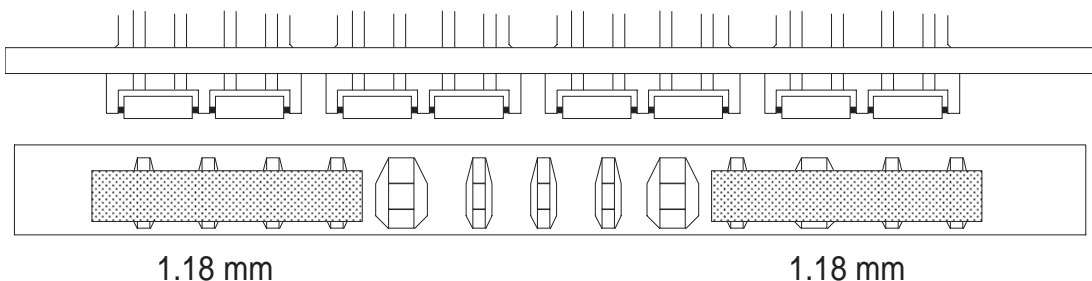

Figure 4-3. PG Lever Operation

Table 4-2. Gap and Adjustment Direction

Gap between Head Nose and Gauge Surface	Move Left Bushing	Move Right Bushing
Too narrow	Clockwise (CW)	Counterclockwise (CCW)
Too wide	Counterclockwise (CCW)	Clockwise (CW)

3. Rotate the parallelism adjustment bushing, attached to the left and right ends of the carriage guide shaft until the black or color printhead contacts the thickness gauge.
4. After placing the printheads against the gauge surface, verify the gap between the carriage flag and the front frame. (See Figure 4-4.)

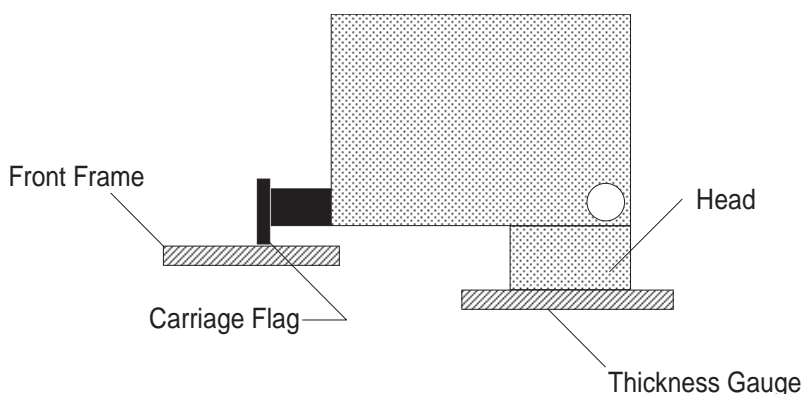

Figure 4-4. Gap Confirmation Method

4.1.5 EEPROM Reset Procedure

Like other EPSON ink jet printers, this printer is equipped with an EEPROM on the main board. This EEPROM stores status information and ink system management parameters. Since the ink system status is unique to each printer mechanism (and the printhead or ink cartridge installed), the information stored in the EEPROM must be consistent with the printer mechanism actually connected to that board. This section provides the procedures to maintain the consistency of the ink status during repair of the printer.

Table 4-3. EEPROM Operation

Service Performed	Operation Required
After replacing the C199 MAIN board.	<input type="checkbox"/> If the printer still works: Refer to Section 4.1.5.1 <input type="checkbox"/> If the printer does not work: Refer to Section 4.1.5.2
After replacing the ink cartridge with a new one (without encountering an Ink End Error).	Refer to 4.1.5.3
After replacing the waste ink pad (without encountering a Maintenance Error).	Refer to 4.1.5.4
After replacing the printhead with a new one.	Refer to 4.1.5.3
Printer indicates a Maintenance Error.	Refer to 4.1.5.4

4.1.5.1 Writing Data to the EEPROM

If the main board needs to be replaced (even if it still works correctly), you need to print out all the data stored in the current EEPROM and write and save the settings to the EEPROM on the new board. This is particularly important to maintain consistency in the status information stored in the EEPROM and the actual status of the printer mechanism.

1. Run adjustment program CLR200.EXE, and select **EEPROM Data Manipulation** from the main menu.
2. Choose **EEPROM DATA DUMP** from the sub menu. The printer prints a dump of the data stored in the EEPROM.
3. When the dump print is complete, choose **EEPROM DATA RESTORE** from the sub menu and input all data printed out. If an EEPROM address is shown on the PC as "--," it is a reserved address and no data input is necessary.



CAUTION

After completing the operation above, perform the Bi-D Alignment and Zig-Zag adjustments.

4.1.5.2 EEPROM Initialization for Main Board Replacement

If the main board malfunctions and is unable to read out the contents of the EEPROM, replace the main board with a new one, and follow the steps below.

1. Replace the ink cartridge currently installed on the printhead with a new one.
2. Replace the waste ink pad with a new one.
3. Reset user setting parameters (see Table 1-13 in Chapter 1).



- Perform the Bi-D Alignment and the Zig-Zag adjustments.
- Never perform the EEPROM clear operation described in Table 1-13 of Chapter 1, because it clears all data stored in the EEPROM, including parameters definable only at the factory.

4.1.5.3 Ink System Initialization

If you replace the ink cartridge or printhead during repair, you must also initialize the ink system status stored in the EEPROM. Since the ink system is managed using status information stored in the EEPROM (i.e., ink consumption, number of flushing operations, etc.), status information becomes inconsistent if you replace the ink cartridge or the printhead without initializing the ink system, and this can cause incorrect error indications or ink system malfunctions.

1. Replace the ink cartridge or the printhead with a new one.
2. Run adjustment program CLR200.EXE, and select EEPROM Data Manipulation from the main menu.
3. If you replaced the ink cartridge, choose INK COUNTER CLEAR from the sub menu, or if you replaced the printhead, choose INITIAL-CHARGE FLAG RESET.

4.1.5.4 Maintenance Error Clear

The ink system monitors the amount of unused ink discarded to the waste ink pad, and when the amount reaches a predefined limit, the printer warns the user by indicating a Maintenance Error. This means the waste ink pad needs to be replaced. If the waste ink pad needs to be replaced, whether or not a Maintenance Error is indicated, follow the steps below to clear the error.

1. Replace the waste ink pad with a new one.
2. Turn the printer off.
3. Turn the printer on while holding down the LOAD/EJECT and CLEANING buttons on the control panel. The Ink End and Paper Out LED lamps start blinking.
4. When these LED lamps start blinking, press the LOAD/EJECT button within 3 seconds and hold it down for 10 seconds or more.
5. Then press the CLEANING button to execute the Maintenance Error Clear operation.



- Be sure to replace the waste ink pad with a new one.

Chapter 5 Troubleshooting

Table of Contents

5.1 OVERVIEW	5-1
5.2 Repair the C160 Power Supply Board	5-3
5.3 Repair the C199 Main Control Board	5-4
5.4 Repair of PRINTER MECHANISM	5-6
5.5 Dot missing Troubleshooting Guide	5-7

LIST OF FIGURES

Figure 5-1. Troubleshooting Construction	5-1
Figure 5-2. Main Flow-Chart for Recover a Dot-missing	5-8
Figure 5-3. 360-DPI Check Pattern	5-9
Figure 5-4. Standard of Dot-missing	5-9
Figure 5-5. The Bent part on the Cap Rubber	5-10

LIST OF TABLES

Table 5-1. Motor Resistance	5-1
Table 5-2. Sensor Status	5-2
Table 5-3. Repair of the C160 PSB/PSE	5-3
Table 5-4. Repair of the C199 Main	5-4
Table 5-5. Repair of the Printer Mechanism	5-6
Table 5-6. Ink Cartridge Exclusive for the Service Side	5-7

5.1 OVERVIEW

This section describes troubleshooting at the unit level and for abnormal printing(missing-aligned dots). The EPSON Stylus Color 200/Epson Stylus 200 uses a new print head that is different from the previous Stylus Color print head. Because of its designs, the status monitor indicates when the cartridge is low or out of ink. If you remove or even partially remove a cartridge unit before it is out of ink, air invades the print head nozzle(s) and the ink cartridge. Once air bubbles clog the nozzle(s), they are very difficult to eliminate. Refer to the Section 5.5 to attempt to clear clogged nozzle(s).

CAUTION

The ink out sensor on the printer is monitored by the firmware counter. If you replace an ink cartridge before its ink sensor is activated, you must clear the EEPROM first.

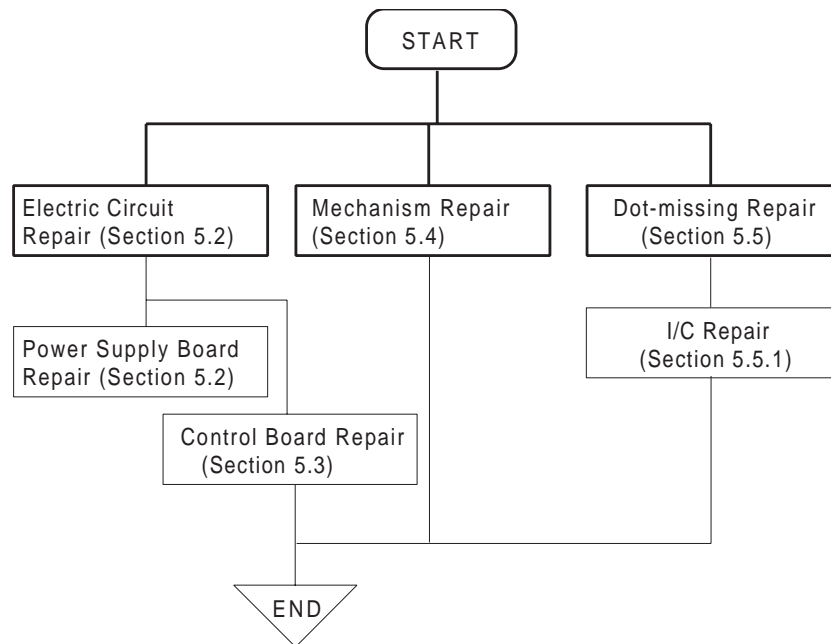

Figure 5-1. Trouble Shooting Construction

Table 5-1. Motor Resistances

Motor	Resistance Range	Temperature
CR Motor	22 Ω \pm 7%	At 25 $^{\circ}$ C (77 $^{\circ}$ F)
PF Motor	21 Ω \pm 1 Ω	At 25 $^{\circ}$ C (77 $^{\circ}$ F)

Table 5-2. Sensor Status

Sensor	Point	Signal Level	Status
PE Sensor	CN7 Pin 1 (PE) to Pin 2 (GND)	H (5 V)	Paper exists
		L (GND)	No paper (paper end)
CO Sensor	CN4 Pin 3 (CO) to Pin 8 (GND)	L (GND)	Cartridge exists
		H (5 V)	No cartridge
M/C Sensor	CN4 Pin 19 (M/C) to Pin 8 (GND)	L (GND)	Color cartridge exists
		H (5 V)	Black cartridge exists
HP Sensor	CN8 Pin 1 (HP) to Pin 2 (GND)	L	At home position (HP)
		H	Out of HP
ASF Sensor	CN9 Pin 1 (ASF) to Pin 2(GND)	L	Manual feed mode
		H	Auto feed mode

5.2 Unit-Repair - C160 Power Supply Board

This section describes how to repair the C160 power supply board and main board. The table below provides various symptoms, likely causes, and check points. The checkpoints refer to waveforms, resistances, and other values to check to evaluate the operation of each component.

Table5-3. Repair of the C160 PSB / PSE

Symptom	Condition	Cause	Checkpoints	Solution
Printer does not operate at all.	+35V line is dead.	F1 is open.	Check the F1.	Replace F1.
		T1 is open.	Check T1 coils using the tester.	Replace T1.
		Q1 is broken.	Check the wave-form at the drain of Q1.	Replace Q1.
		Q2 or Q3 is broken.	Check the wave-form at the drain of Q2 and Q3.	Replace Q2 or Q3.
		PC1 is broken.	Check the wave-form at 3-pin of PC1.	Replace PC1.
+5V is dead.	L4962 is broken.	Check the oscillation at 5-pin of IC51.	Replace IC51.	
		Check the output wave-form at 7-pin of IC51.	Replace IC51.	

5.3 Unit Repair - C199 Main Control Board

This section describes the problems related to the main controller board (C199 Main). The table below provides various symptoms, likely causes, and checkpoints. The checkpoints refer to waveforms, resistance, and other values to be checked to evaluate the operation of each component.

Table 5-4. Repair of C199 MAIN

Phenomenon	Condition	Cause	Checkpoints	Solution
It does not operate at all.	CPU does not operate.	Reset circuit does not operate.	Check the wave-form at either pin 1 and 4(GND). 	Replace IC13.
		CRU1 or IC2 is defective.	Does wave-form of CRU1 is correct? (at either pin 37 and 38 of CPU) 	Correct : replace IC2. Incorrect : replace CRU1.
	Gate array does not operate.	CRU2 or IC1 is defective.	Does wave-form of CRU2 is correct? (Refer to above wave-form.) 	Correct : replace IC1. Incorrect : replace CRU2.
Self-test printing does not abnormal.	Gate array does not operate.	OE signal does not output.	Check the wave-form at the pin (52,54,56,57,58). 	Replace IC1.
		PWM signal does not output.	Does PWM wave-form is correct? (Check the pin at 140.) 	Replace IC1.
	Common driver circuit does not operate.	Tr does not operate.	Check the wave-form at the pin 3 of QM3. 	Replace a defective element.(QM1,2,3,4, 5,6,7,8 or Q1,7,8.)

Table 5-4. Repair of C199 MAIN(Cont.)

Phenomenon	Condition	Cause	Checkpoints	Solution
Carriage does not operate normally.	Drive pulse does not output.	CPU is defective.	Does the wave-form correct? (Check pin either at 9 and 10.) 	Replace CPU.
		IC12 is defective.	Does the wave-form correct? (Check pin at 17,20 and 14,23.) 	Correct : replace motor. Incorrect : repalce IC12.
PF motor does not operate normally.	Drive pulse does not output.	CPU is defective.	Does the wave-form correct? (Check pin either at 3 and 4.) 	Replace CPU.
		IC16 is defective.	Does the wave-form correct? (Check pin at 17,20 and 14,23.) 	Correct : replace motor. Incorrect : repalce IC12.

5.4 Repair of PRINTER MECHANISM

Any problems related to the printer mechanism should be repaired according to the troubleshooting procedures in Table 5-5.

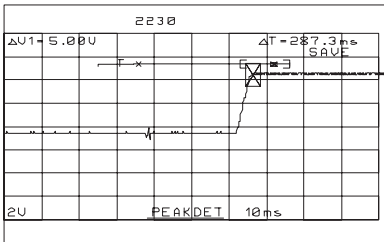
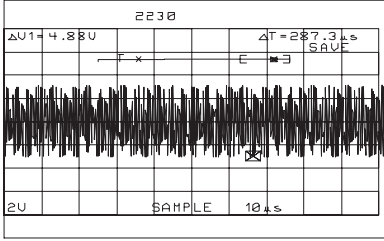
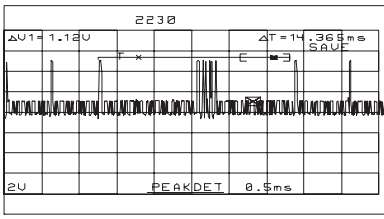
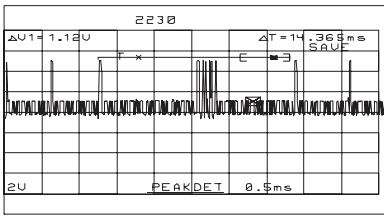
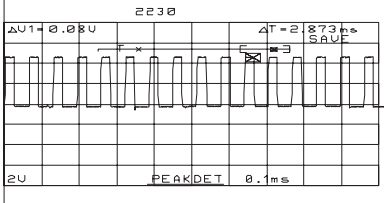
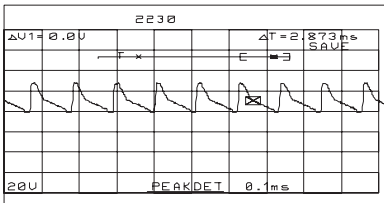
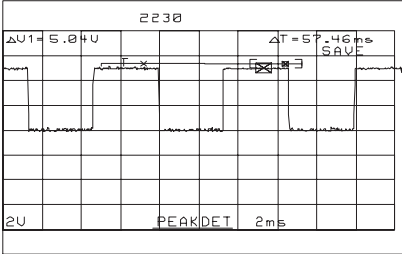
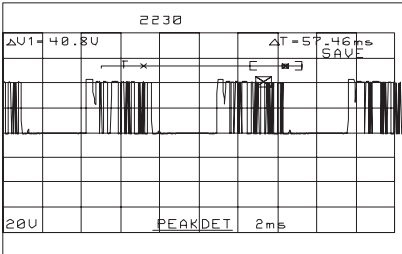
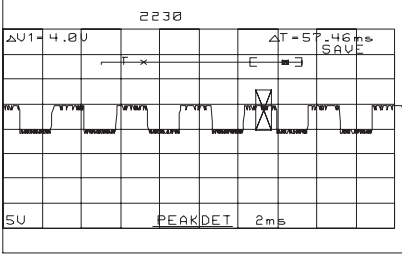
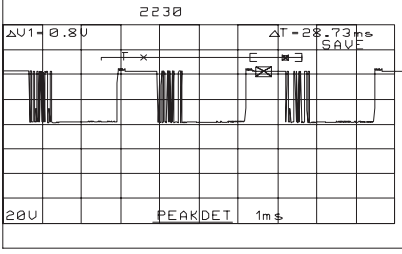
Table 5-5. Repair of the Printer Mechanism

Symptom	Condition	Cause	Checkpoint	Solution
The pump mechanism does not operate.	The PF motor fails to rotate at power on.	PF motor is defective.	Measure the coil resistance of the CR motor. 21 Ω ± 1Ω	Remove any foreign substance.
		Carriage flag is defective.	Check the flag on the back of the carriage unit.	Replace the carriage unit.
	Used ink does not go through the used ink tube during the cleaning operation.	The tube is not properly connected to the cap.	Check that the tube is properly connected to the cap.	Insert the tube properly.
		The ink tube is damaged.	Check the ink tube visually.	Replace the tube.
		The cap is defective.	Check for any defective part.	Replace the head cap.
		The pump is defective.	Replace the pump to see if this causes the ink to be absorbed normally.	Replace the pump unit.
		The printhead is defective.	Replace the printhead to see if this causes the ink to be absorbed normally.	Replace the printhead.
The carriage motor does not rotate.	The carriage motor fails to rotate at power on.	PG value is incorrect.	Check the PG value. (1.18 mm ± 1/100)	Remove any foreign substances.
		CRHP sensor is defective.	Check voltage reaction at pin 1 on CN8.	Replace CRHP.
		The carriage motor is defective.	Measure the coil resistance of the CR motor. 22 Ω ± 7%	Replace the carriage motor.
The carriage does not operate normally at power on (after the carriage has been manually centered prior to power on).	The carriage motor rotates, but the carriage does not move.	The pulley is defective.	Check for broken or worn pulley.	Replace the driven pulley.
		The timing belt is defective.	Check that the timing belt is properly inserted into the bottom of the carriage.	Reinsert the timing belt.
	Check the timing belt for any damage.		Replace the timing belt.	
	The carriage moves slightly and then stops.	Carriage movement is not smooth.	Check whether the carriage moves smoothly when moved manually.	Clean and lubricate the carriage.
			Check tension of the timing belt.	Adjust tension of the timing belt.

5.5 Dot missing Trouble shooting Guide

This section describes how to recover the clogged nozzle when you receive the dot-missing printer.

Since the print head of this printer is the new system, it is very difficult to eliminate the invaded air bubble from the print head unit or the ink cartridge so that, never use again if you remove once a ink cartridge from the main unit.

Also, we prepare the special ink cartridge exclusive for your service side. Please refer to the following table for low price ink cartridge.

Table 5-6. Ink Cartridge exclusive for the service side

Ink Cartridge	Code
Black ink cartridge	1023206
Color Ink cartridge	1029341



- Do not re-use a removed ink cartridge when you return the printer to your user.
- Since the ink end sensor is counted by the firmware counter, there is a possibility that “Ink low” or “Ink out” error indications might appear. Therefore, make sure to reset the EEPROM (firmware counter) after the ink cartridge is replaced. Also, the waste ink drain pad should be replaced according to its conditions.



- Only when the printhead is installed for the first time, individual dummy CL sequences for black and color head need to be done initial charge. However, once initial charge is done, it can not be done unless the initial charge flag in the EE-PROM is reset. Therefore, either perform this initial charge by using adjustment program or reset the EEPROM by the panel operation. It is encouraged to use the adjustment program since the panel reset requires additional adjustments.
- There are two reset methods to clear the EEPROM. Select a proper method according to the following conditions.
 - *Maintenance error status: Reset by the panel

*Normal status (No-error status): Reset by the adjustment program

5.5.1 How to recover the dot-missing with the brand-new ink cartridge

The following flow-chart shows the way of recovering a clogged nozzle with the ink cartridge. The section that is indicated out of each items shows the additional explanation when you need more information..

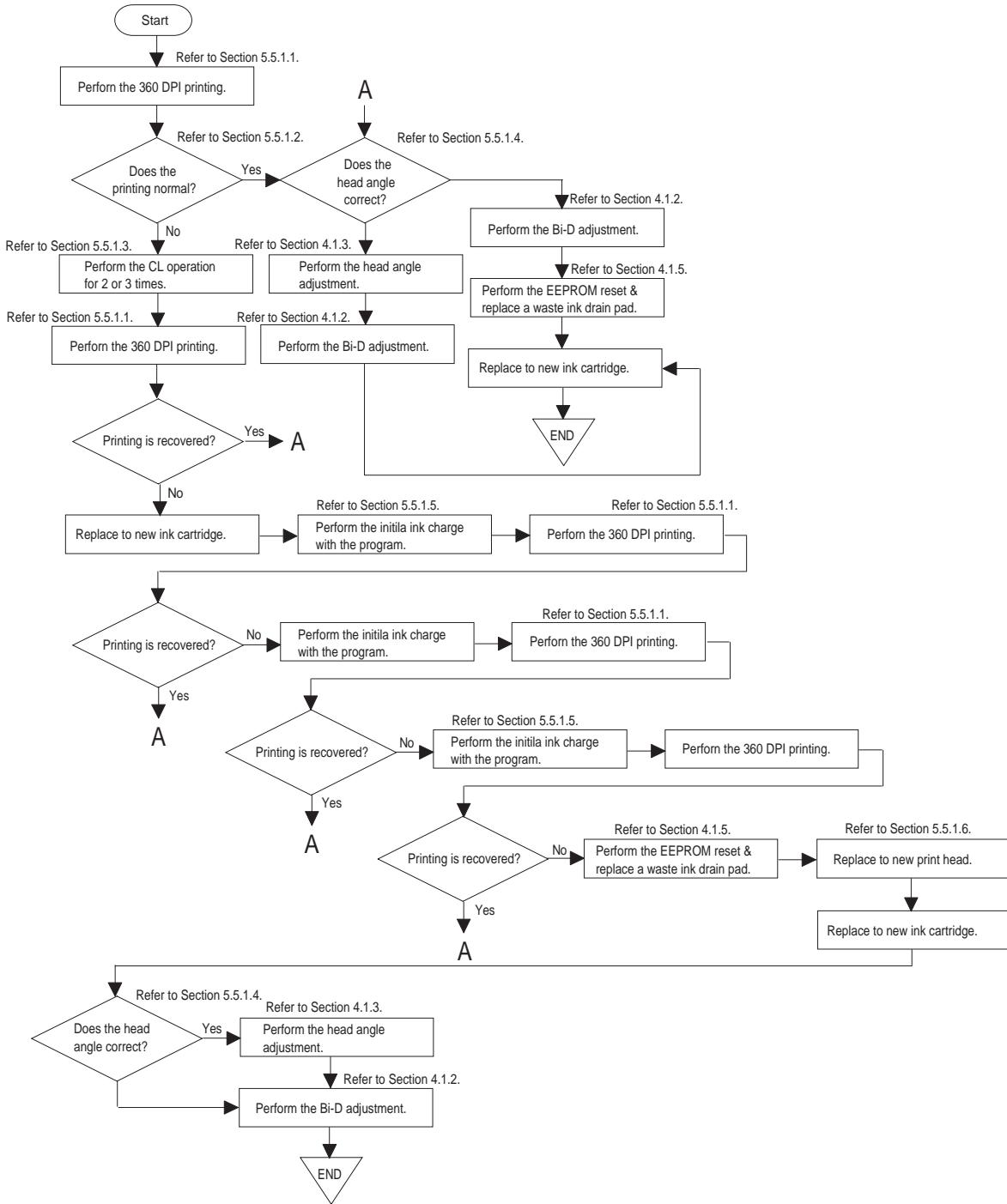

Figure 5-2. Main Flow-Chart for Recover a Dot-missing

5.5.1.1 How to Perform the 360-DPI Printing

It is possible to confirm the any problems with the 360-DPI check pattern printing. Also, if you receive the white banding problem, you can confirm the wrong condition quickly. Please perform the proper repair referring under explanations.

- [Step 1] Connect the host computer to the printer with the printer cable.
- [Step 2] Insert the paper to the hopper and load a paper.
- [Step 3] .Execute the adjustment program"CLR200.EXE" and select "Print CHECK-PATTERN". The printer print the chekc pattern as shown below.

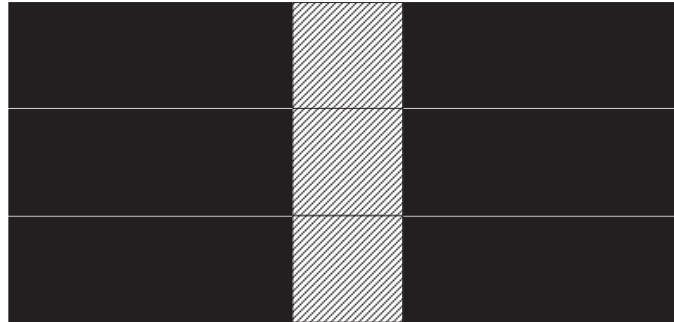

Figure 5-3. 360-DPI Check Pattern

5.5.1.2 Standard of "Is the printing normal?"

If the 360-DPI printing pattern has a following problem, advance to next step on the flow chart.(Section 5.5.1.3)

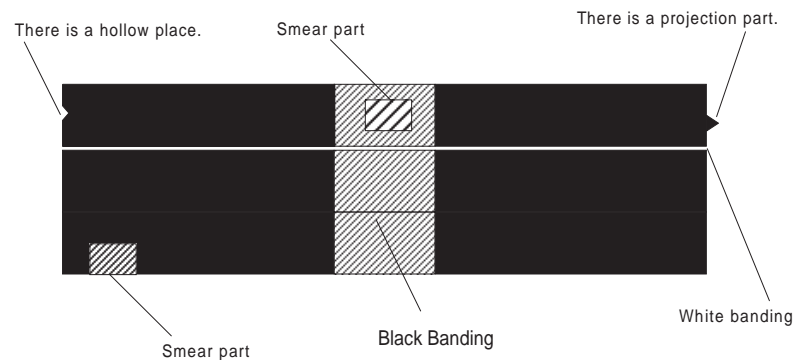

Figure 5-4. Standard of Dot-missing

5.5.1.3 Performing the CL operation for 2 ~ 3 times

This section describes the cleaning operation if you find a print missing on the 360-DPI check pattern. You need a confirmation either the CL operation is correctly performed or not in this function..

- [Step1] Perform the CL operation. (Under the pause state, pressing the Clening button)
- [Step2] Pay attention to the sponge in the cap either the ink is correctly supplied or not (In case of color head installed, the color of YMC becomes clear from the right side. In case of black head installed, the sponge becomes black evenly.)
- [Step3] If an ink is not correctly supplied, check the under items before you advance to next step before going to the next step on the main flow chart.

- Observing the cap from above, make sure there are not any bents , holes or scars on the surface.

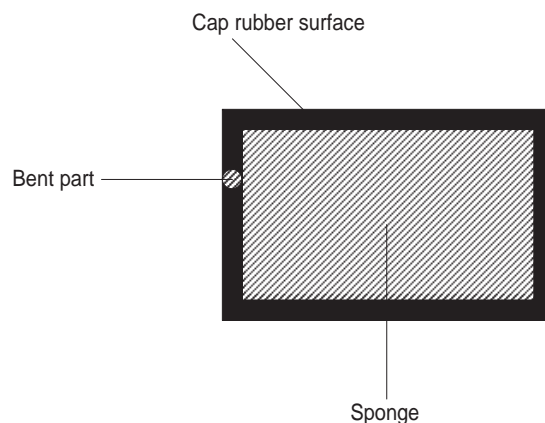

Figure 5-5. The Bent part on the Cap rubber

Note: *If you can not find any problems about the pump unit system or the above contents, there is a possibility that an ink in the ink cartridge has already emptied in spite of any counter values, so that it is necessary to replace to the brand-new ink cartridge. Also, if user perform removing or installing with the same ink cartridge, it will not recover the dot-missing every time you perform the CL operation, because the constructure of the print head is very complex as compair to previous head system. Therefore, replace to the brand-new ink cartridge at this time.*

5.5.1.4 Is the Head angle correct?

This section describes either the head angle condition is correct or not. Refer to Section 4.1.3 for the actual adjustment.

[Step 1] Perform the head angle adjustment. (Refer to Section 4.1.3.)

Note: If the head angle condition is wrong, white or color banding problem will be appeared on the graphic pattern.

5.5.1.5 Initial charge operation

Since the status, whether the initial charge operation has been performed or not, is stored in the EEPROM, you have to clear this with the adjustment program to perform the initial charge operation again on the same printer.

[Step 1] Execute the adjustment program "CLR200.EXE" and select "EEPROM Data Manipulation".

[Step 2] Choose "INITIAL-CHARGE FLAG RESET" from the sub menu.

[Step 3] Install new printhead and new ink cartridge on the printer. Then turn the printer on to start the initial-charge operation.

5.5.1.6 Replace to new ink cartridge

It is necessary to replace the print head unit if you can not recover alogged nozzle by performing the initial ink charge, CL operation and replacing the new ink cartridge.

If you replace to new ink cartridge, do not re-use a removed ink cartridge again.

Chapter 6 Maintenance

Table of Contents

6.1 PREVENTIVE MAINTENANCE	6-1
6.1.1 Printhead Cleaning	6-1
6.1.2 Waste Ink Drain Tank Replacement	6-2
6.1.3 Lubrication and Adhesives	6-3

LIST OF FIGURES

Figure 6-1. Lubrication Points and Adhesive Points	6-4
--	-----

LIST OF TABLES

Table 6-1. Recommended Lubricants	6-3
Table 6-2. Lubrication Points	6-3
Table 6-3. Adhesive Points	6-3

6.1 PREVENTIVE MAINTENANCE

This printer must be lubricated only **O-11** when you need a lubrication for carriage guide shaft. If you lubricate with another oil, it could permanently damage the print head unit..

Although this printer requires no specific maintenance on a regular basis, recommends that you clean the following thoroughly whenever you get a chance.:

Outer case

Use a soft, clean cloth, dampened with mild detergent, if necessary.

Auto sheet feeder

If the inside of the auto sheet feeder is dirty (dusty), carefully brush away all dust and dirt using a soft brush. If the pickup roller of the sheet feeder is dirty, clean its surface with a soft, clean cloth.

Inside the printer

If you notice any dust or dirt that has accumulated inside the printer when you open the outer case for repair, remove all dust and dirt using a small vacuum cleaner designed for such purposes.

WARNING

- Use only **O-11** oil when lubricating the carriage guide shaft. If you lubricate with another oil, it could permanently damage the print head unit.
- Never use paint thinner, trichloroethylene, or ketone-based solvents for cleaning. These chemicals can damage the components the printer.
- Do not use a hard or abrasive brush for cleaning.
- Be careful not to damage the components of the printer when using a vacuum cleaner.
- If ink gets into your eyes, flush them immediately with clean water and ask for medical attention.
- Disconnect the printer from the power source when you clean inside the printer.

CAUTION

- Once removed ink cartridge must be replaced to the brand-new cartridge when the printer is sent back to the user. (Refer to the following ink cartridge code)
 - Black: 1023206 , Color: 1029341
- When the printer is sent back to the user or during the transport, the cartridge should remain to be installed in the main unit. Since protective material is required to protect carriage during the transport, it should be ready for availability.
- It is encouraged to use the adjustment program to adjust the head angle and location when the print head is replaced.

6.1.1 Printhead Cleaning

If print quality deteriorates, clean the printhead using the built-in printhead cleaning function. The printer also has an automatic printhead cleaning cycle to ensure proper nozzle operation for ink ejection and to preserve the printhead in the best condition. Performing the cleaning more often wastes ink.

1. Turn the printer on and press the Cleaning button. The Power light flashes during this cycle and then stays on when it is finished.
2. Turn off the printer.

3. Hold down the Load/Eject button as the printer is turned back on. This prints a demonstration page in order to check the result.
4. Turn off the printer to exit demonstration mode.



If the cleaning operation is performed more than 4 times continuously, ink is not absorbed because of dummy CL sequence function. Therefore, if cleaning operation is required more than 4 times, it should be restarted after printing something out once, such as self-test or demonstration page.

6.1.2 Waste Ink Drain Tank Replacement

The printer counts the total amount of ink drained to the waste ink tank, and this information is stored in the EEPROM on the main board (Protect counter A) for ink system operation management. If the value of this counter reaches a predetermined value, all three lights blink and indicate error status. ("Maintenance request," see Chapter 1, Error indications, Table 1-15). When this error is displayed, replace the waste ink drain pad and reset the protect counter.

1. Remove the printer mechanism (Refer to 3.2.5) and replace the waste ink tank located in the waste ink tank.
2. After reassemble the printer, take following steps in order to reset the protect counter.
3. ⇨ Turn the printer on while holding down the Cleaning and Load/Eject buttons.
⇨ Within 3 seconds after ⇨ procedure, hold down Load/Eject button for 10 seconds. (until Ink out and Paper out lights start blinking)
4. Under this condition, press the Cleaning button, then initialize operation will be automatically performed.



☐ Since the value of counter is stored in EEPROM, the waste ink pad must be replaced when the main board is replaced. Otherwise, ink might leak from the waste ink tank while printing.

6.1.3 Lubrication and Adhesives

The printer must be lubricated properly when it is disassembled for component replacement, or if mechanical noise exceeds a certain level. EPSON recommends only the lubricants listed in table below for this printer. They have been tested extensively and found to comply with the requirements of this printer mechanism. Figure 6-1 shows the lubrication points.

Use only O-11 oil when lubricating the carriage guide shaft. If you lubricate with another oil, it could permanently damage the print head unit.

Table 6-1. Recommended Lubricants

Type	Name	Quantity	Part No.	Availability
Oil	O-11	40 cc	1031220	E
	G-36	40 gm	B703600001	E
Adhesive	NEJI LOCK #2 (G)	1000 g	B730200200	E

Note: E = EPSON Exclusive product (not commercially available)

Table 6-2. Lubrication Points

Ref. No.	Lubrication Point	Name/Quantity
(1)	Oil pad on the carriage	O-11(0.2 cc)
(2)	Pick up roller hole on the Pump unit	G-36 (1-3 mg)
(3)	Both sides of the platen unit	G-36 (1-3 mg)
(4)	Pump transmission gear (Black color)	G-36 (1-3 mg)
(5)	Clutch mechanism (Between PF and pump)	G-36 (1-3 mg)
(6)	Left shaft on the paper feed roller unit	G-36 (1-3 mg)
(7)	E-ring on the paper feed roller unit (Right side)	G-36 (1-3 mg)
(8)	Pump transmission gear surface	G-36 (1-3 mg)
(9)	Rail surface on the paper select lever	G-36 (1-3 mg)

Table 6-3. Adhesive Points

Ref. No.	Adhesive Point	Name/Quantity
(1)	A part of timing belt securing on the carriage unit	#2 (G) (1-3 mg)

Do not apply too much lubricant. Too much lubrication may stain the printer or cause a malfunction of the mechanism.
 Apply lubrication on only listed points above. Lubrication for the other points may cause damage to the mechanism.

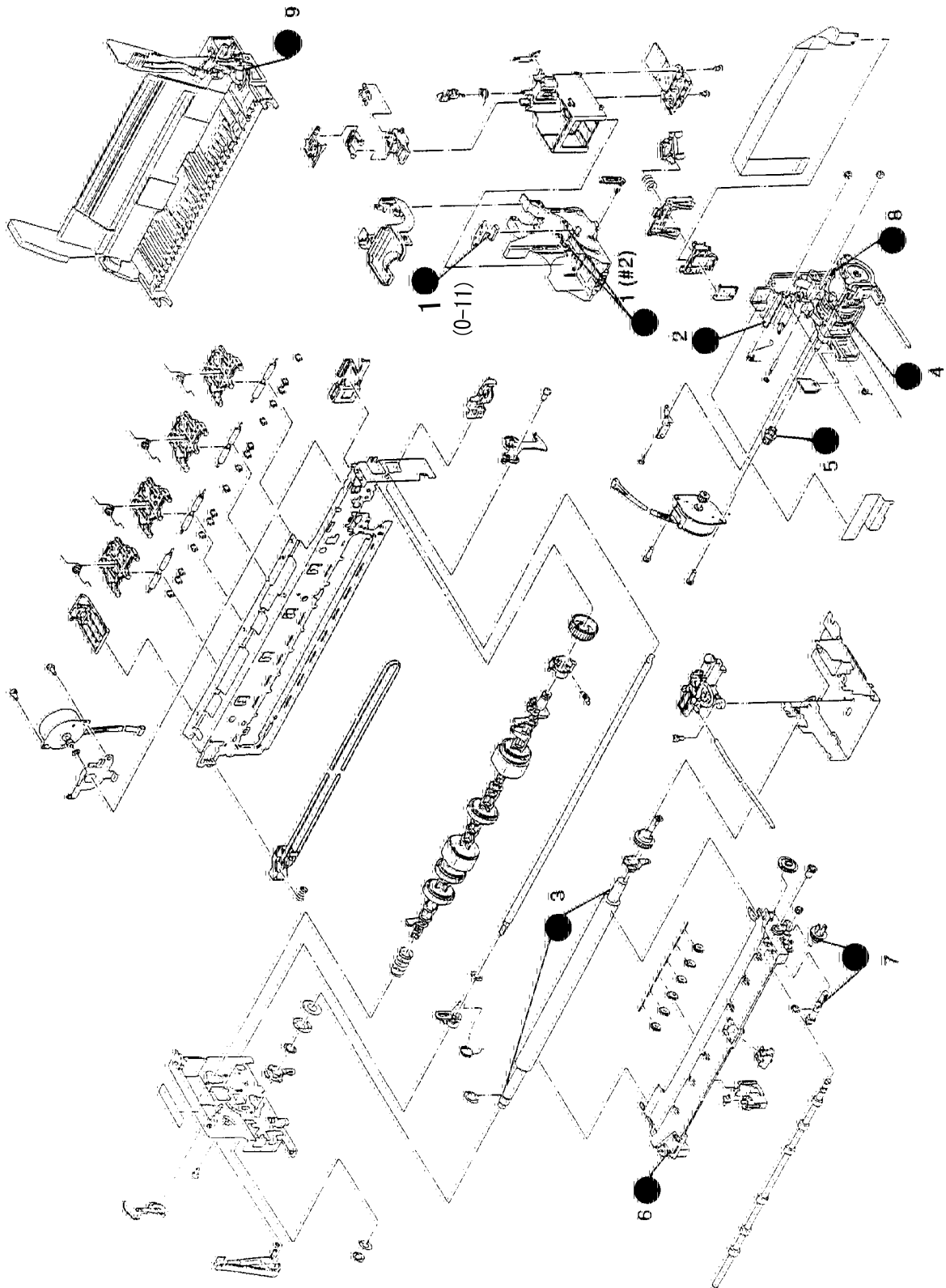

Figure 6-1. Lubrication and Adhesive Point

Appendix

Table of Contents

A.1 CONNECTOR SUMMARY	A-1
A.1.1 Detail of Connector Summary	A-2
A.2 CIRCUIT DIAGRAMS	A-5
A.3 CIRCUIT BOARD COMPONENTS Layout	A-10
A.4 EXPLODED DIAGRAMS	A-11

LIST OF FIGURES

Figure A-1. Interconnection of Major Components	A-1
Figure A-2. C160 PSB Board Circuit Diagram	A-5
Figure A-3. C160 PSE Board Circuit Diagram	A-6
Figure A-4. C199 Main Control Board Circuit Diagram.....	A-7
Figure A-5. C160 PSB Board Component Layout	A-9
Figure A-6. C160 PSE Board Component Layout	A-9
Figure A-7. C199 MAIN Control Component Layout.....	A-10
Figure A-8. EPSON Stylus Color 200 Exploded Diagram (1)	A-11
Figure A-9. EPSON Stylus Color 200 Exploded Diagram (2)	A-12
Figure A-10. Stylus Color IIs(820) Exploded Diagram (3).....	A-13

LIST OF TABLES

Table A-1. Connector Summary	A-2
Table A-2. Connector Pin Assignments – CN1	A-2
Table A-3. Connector Pin Assignments – CN2	A-3
Table A-4. Connector Pin Assignments – CN3.....	A-3
Table A-5. Connector Pin Assignments – CN4	A-3
Table A-6. Connector Pin Assignments – CN5	A-4
Table A-7. Connector Pin Assignments – CN6	A-4
Table A-8. Connector Pin Assignments – CN7	A-4
Table A-9. Connector Pin Assignments – CN8	A-4
Table A-10. Connector Pin Assignments – CN9	A-4

A.1 CONNECTOR SUMMARY

The figure below shows the interconnection between the major components of the Epson Stylus Color 200/Epson Stylus 200.

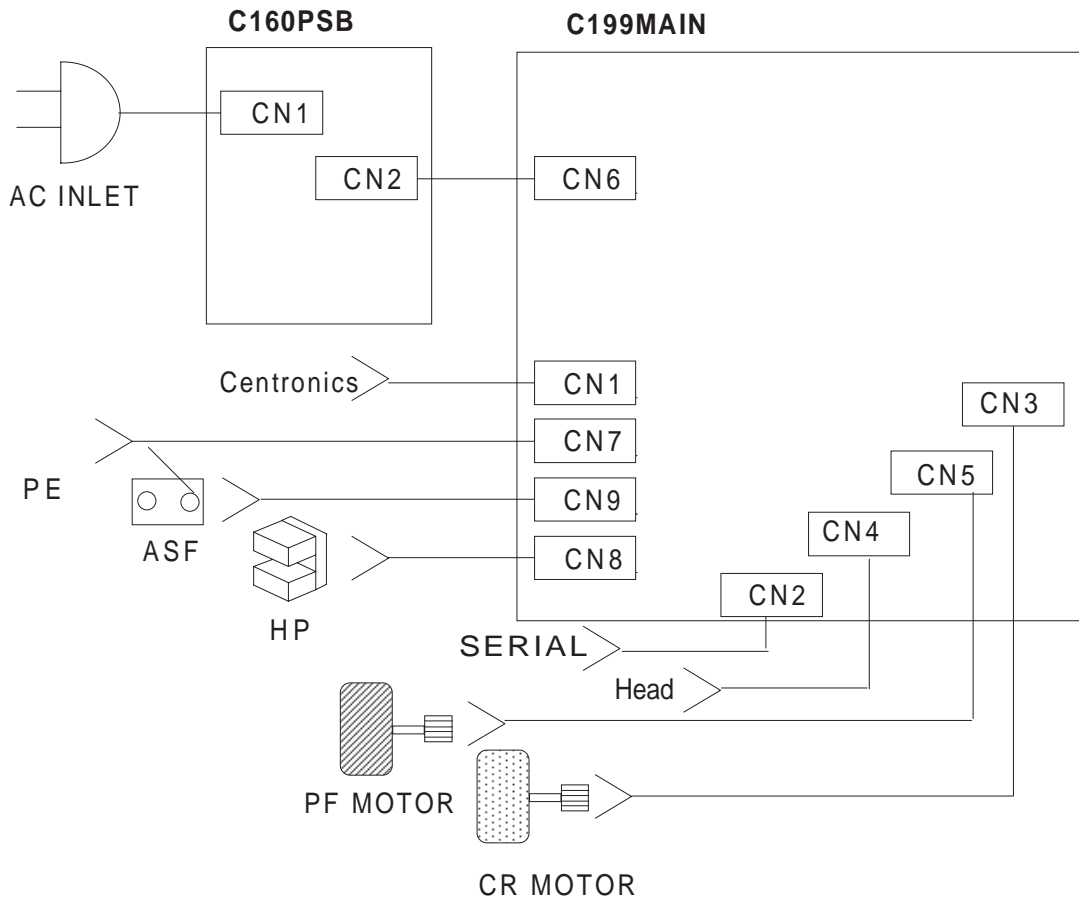

Figure A-1. Interconnection of Major Components

A.1.1 Connector Summary

This section describes the connector summary. The table A-1 lists the connector summary for every connectors on the C199 main and the C160 power supply board. Also, the table A-2 to table A-10 lists the detail signals for every connectors.

Table A-1. Connector Summary

Board	Location	Pin	Description
C199 MAIN	CN1	36	Centronics I/F
	CN2	36	Serial I/Fn (Not Connected)
	CN3	4	Carriage Motor Control
	CN4	19	Head Control
	CN5	4	Paper Feed Motor Control
	CN6	5	Power Supply from C160 PS board
	CN7	2	PE Sensor
	CN8	3	Carriage Home Position Sensor
	CN9	2	ASF sensor
C160 PSB/PSE	CN1	2	AC inlet (L/N)
	CN2	8	DC output (+5 V / +35 V)

Table A-2. Connector Pin Assignments - CN1

Pin	I/O	Name	Description
1	—	GND	Ground
2	—	FG	Frame Ground
3		LOGH	Logic Hights
4	I	-AFXT	Auto line feed signal
5	—	+5V	+5VDC
6	O	SLCT	Printer select signal
7	I	-SLIN	Select in signal
8		PE	Paper end
9	O	-ERR	Error signal
10	O	BUSY	Busy signal
11	I	-INIT	INIT signal
12	O	-ACK	ACK signal
13	I	-STB	Strobe signal
14		D7	Data bit 7
15		D0	Data bit 0
16		D6	Data bit 6
17		D1	Data bit 1
18		D5	Data bit 5
19		D2	Data bit 2
20		D4	Data bit 4

Table A-3. Connector Pin Assignments — CN2

Pin	I/O	Name	Description
1	I	DTR	Data terminal ready signal
2	O	TXD-	Transmit data signal
3	—	GND	Signal Ground
4	I	RXD-	Receive data signal
5	O	TXD+	Transmit data signal
6	I	RXD+	Receive data signal

Table A-4. Connector Pin Assignments — CN3

Pin	I/O	Name	Description
1	O	CR-A	Carriage motor drive phase A
2	O	CR-/A	Carriage motor drive phase /A
3	O	CR-B	Carriage motor drive phase B
4	O	CR-/B	Carriage motor drive phase /B

Table A-5. Connector Pin Assignments — CN4

Pin	I/O	Name	Description
1	—	FG	Frame ground
2	—	VDD	+5VDC
3	I	CO	Cartridge In/Out sensor
4.6.8	—	GND	Ground
5	O	HCLK	Head clock signal
7	O	LATCH	Head latch signal
9	O	SI	Serial data signal
10	I	ID4	Head ID signal
11.12	—	GND2	Ground (for head control voltage)
13.14	O	COM	Head voltage
15	I	ID1	Head ID signal
16	I	ID2	ID code (Vh level auto-selection)
17	I	ID3	ID code (Vh level auto-selection)
18	I	TH	Thermister analog data
19	I	M/C	Black or Color detection sensor

Table A-6. Connector Pin Assignments — CN5

Pin	I/O	Name	Description
1	O	PFA	PF motor drive phase A
2	O	PF-/A	PF motor drive phase /A
3	O	PF-B	PF motor drive phase B
4	O	PF-/B	PF motor drive phase /B

Table A-7. Connector Pin Assignments — CN6

Pin	I/O	Name	Description
1.5	I	+42VDC	Power voltage supply from power supply board
2.4	—	GND	Ground
3	I	+5VDC	Logic voltage supply from power supply board

Table A-8. Connector Pin Assignments — CN7

Pin	I/O	Name	Description
1	I	PE	Paper in/out state detection signal
2	—	GND	Ground

Table A-9. Connector Pin Assignments — CN8

Pin	I/O	Name	Description
1	I	HP	Home position detection signal
2	—	GND	Ground
3	O	HPV	+5VDC

Table A-10. Connector Pin Assignments — CN9

Pin	I/O	Name	Description
1	I	ASF	Auto sheet Feed sensor
2	—	GND	Ground

A.2 CIRCUIT DIAGRAM

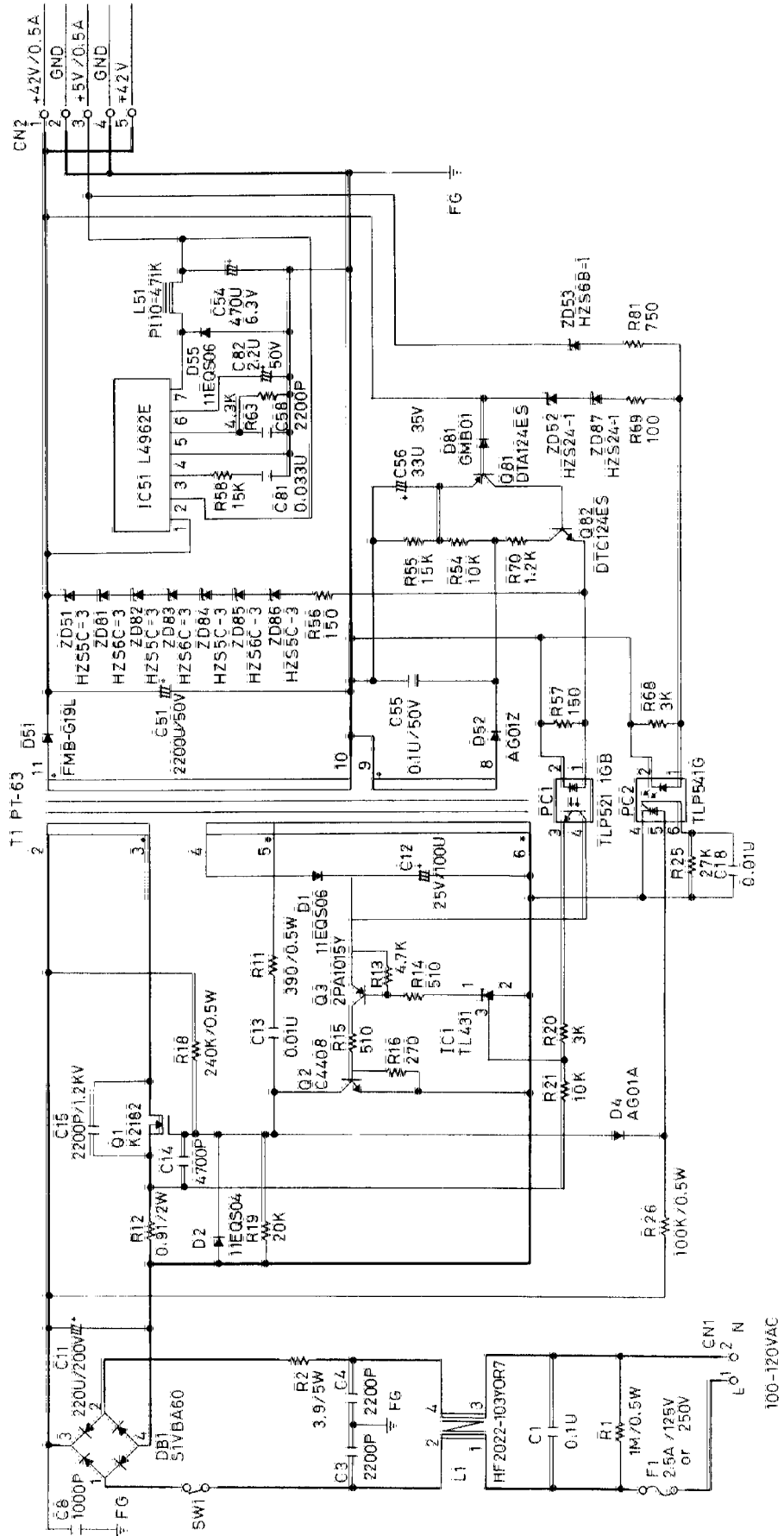

Figure A-2. C160 PSB Board Circuit Diagram

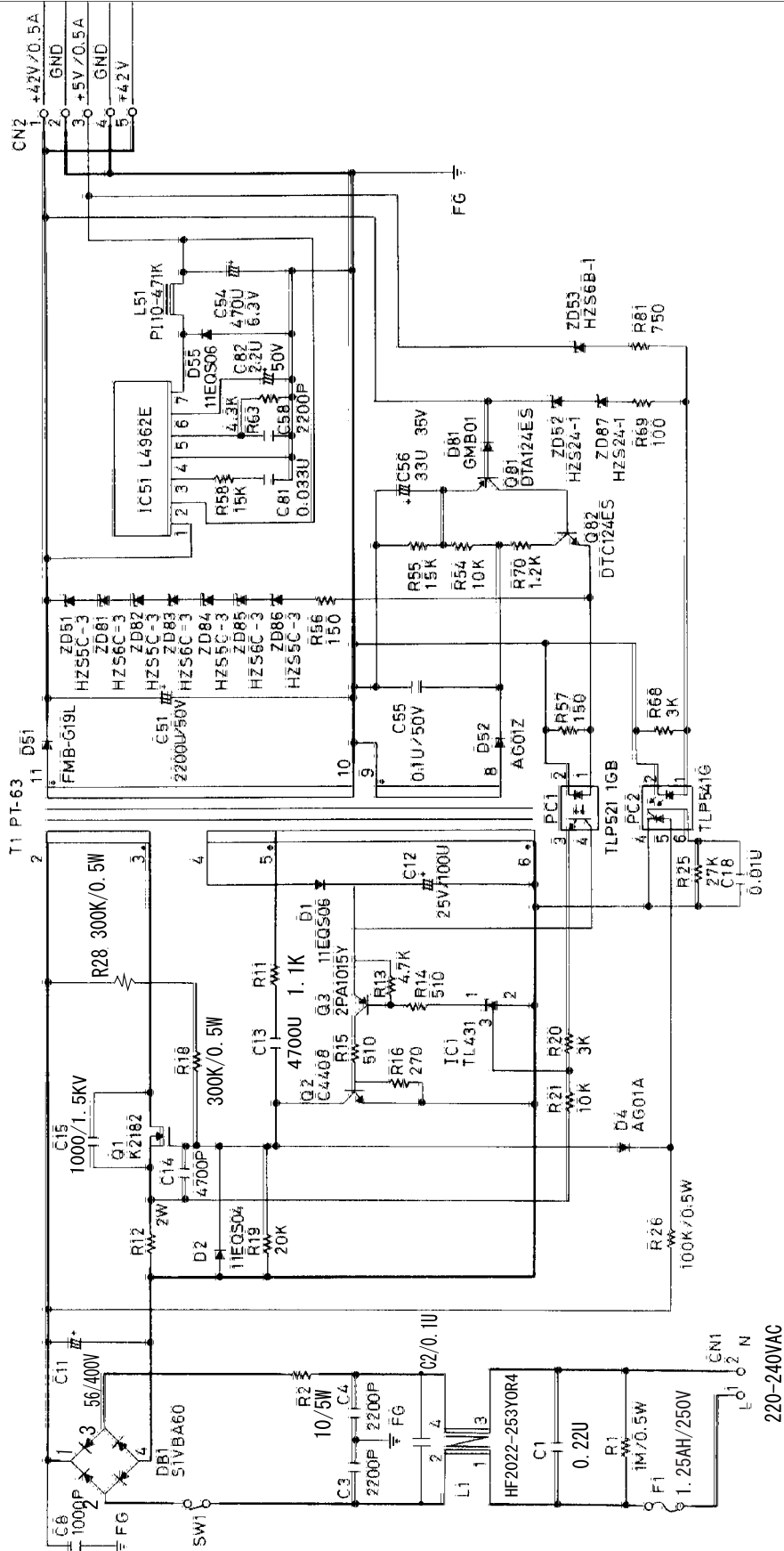

Figure A-3. C160 PSE Board Circuit Diagram

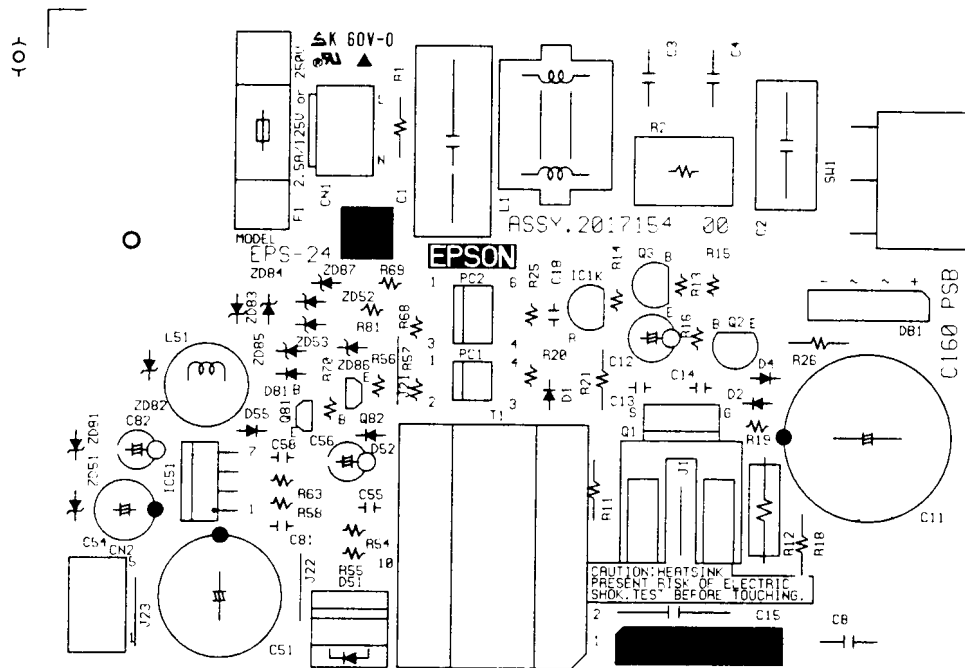

Figure A-5. C160 PSB Board Component Layout

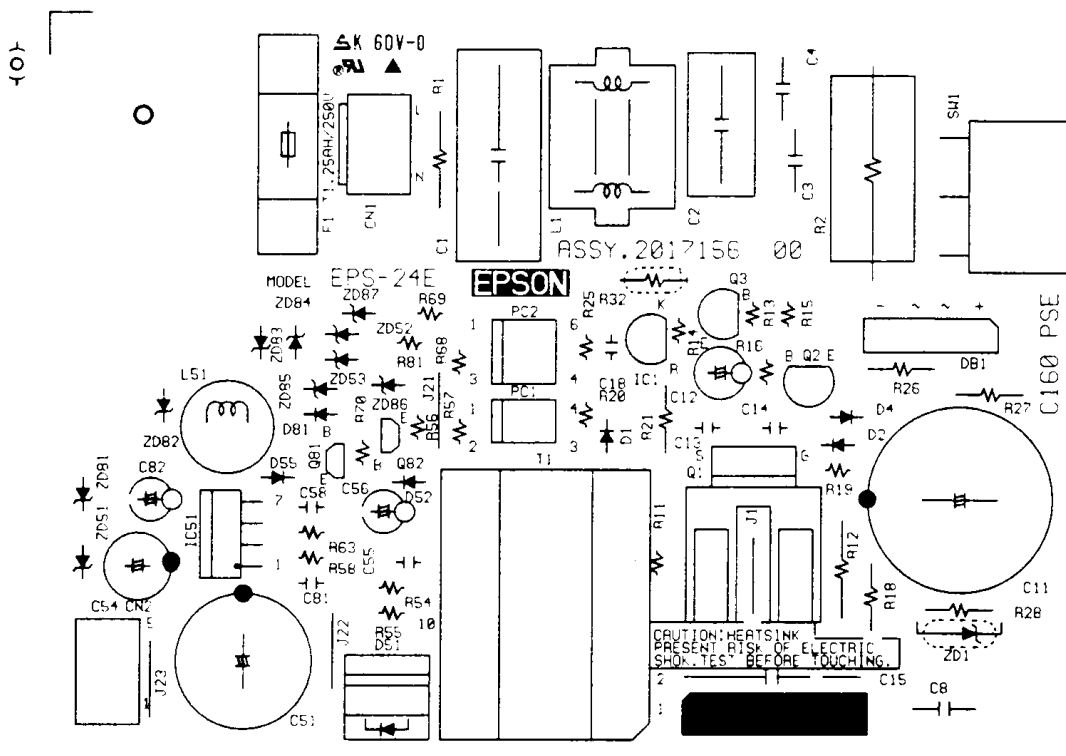

Figure A-6. C160 PSE Board Component Layout

A.3 Circuit Board Component Layout

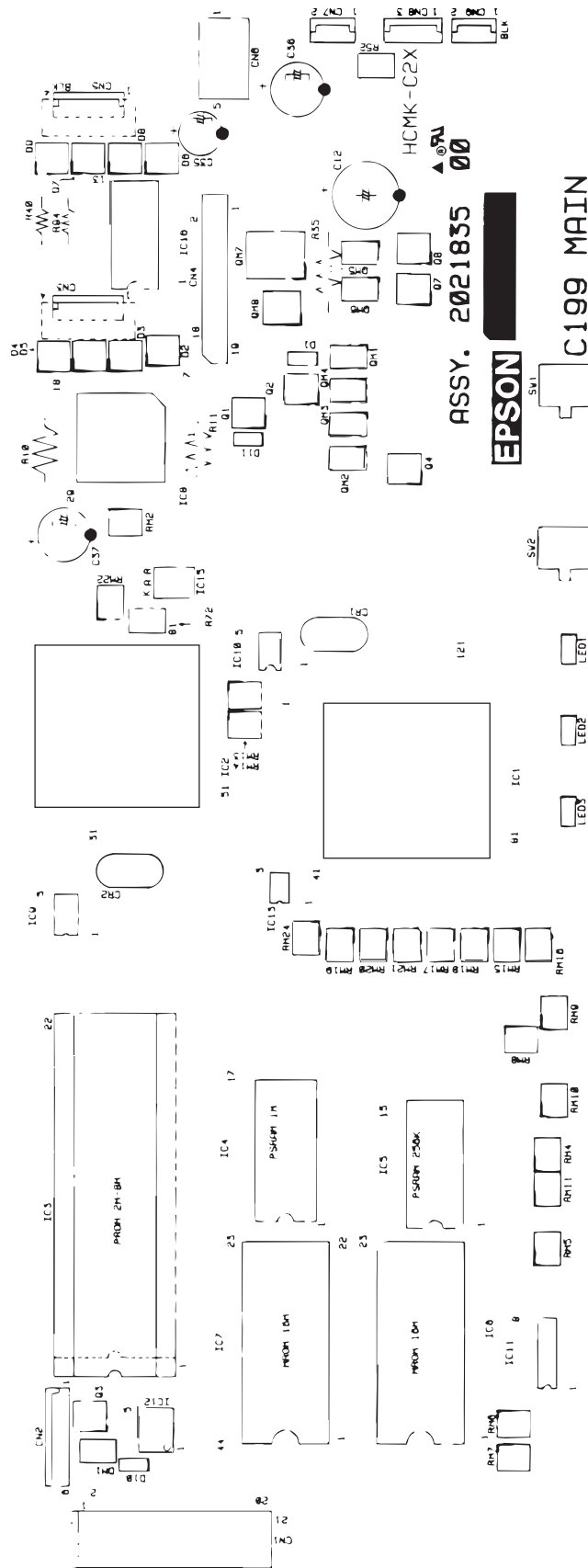

Figure A-7. C199 Main Control Board Component Layout

A.4 Exploded Diagram

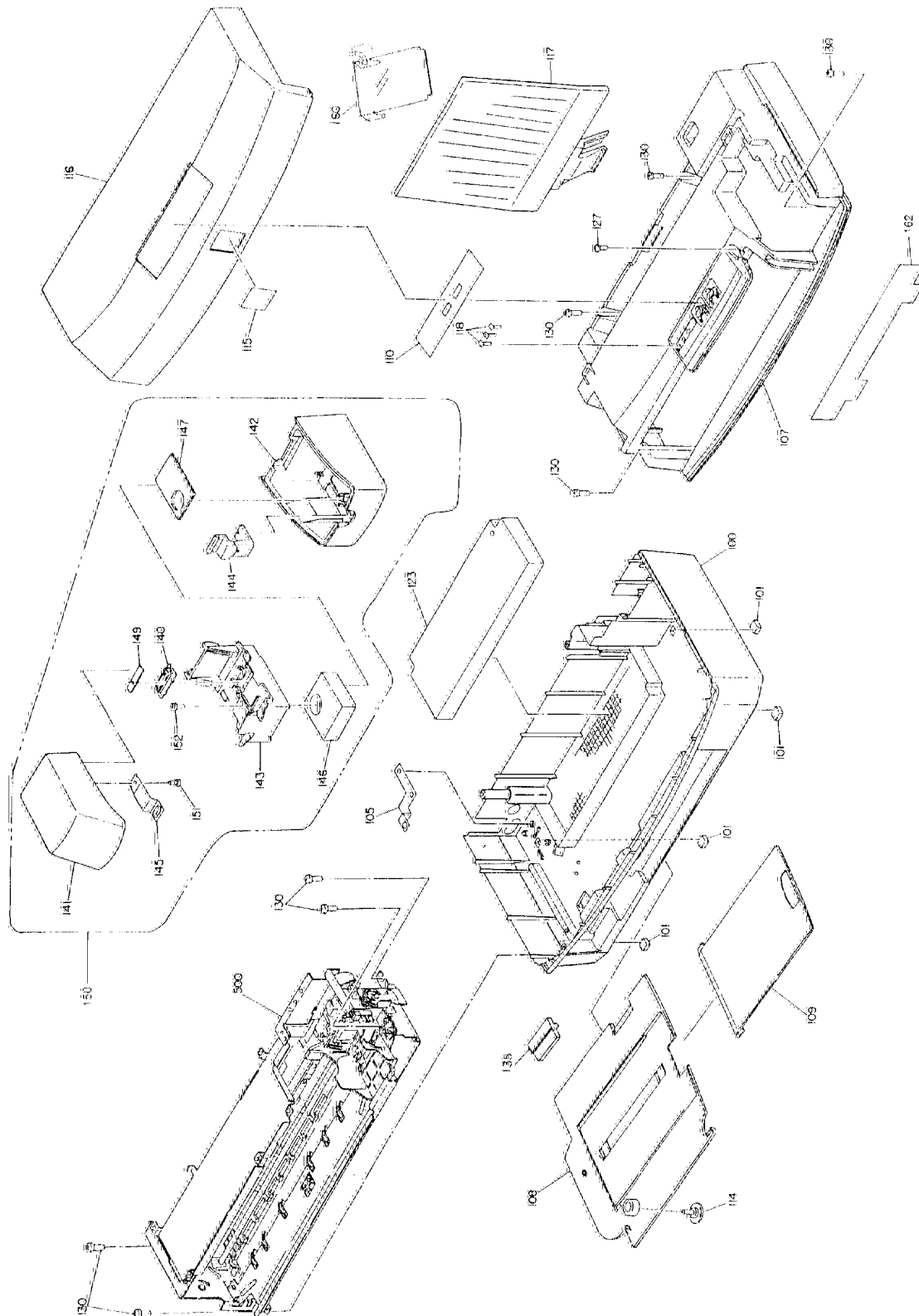

Figure A-8. EPSON Stylus Color 200 Exploded Diagram (1)

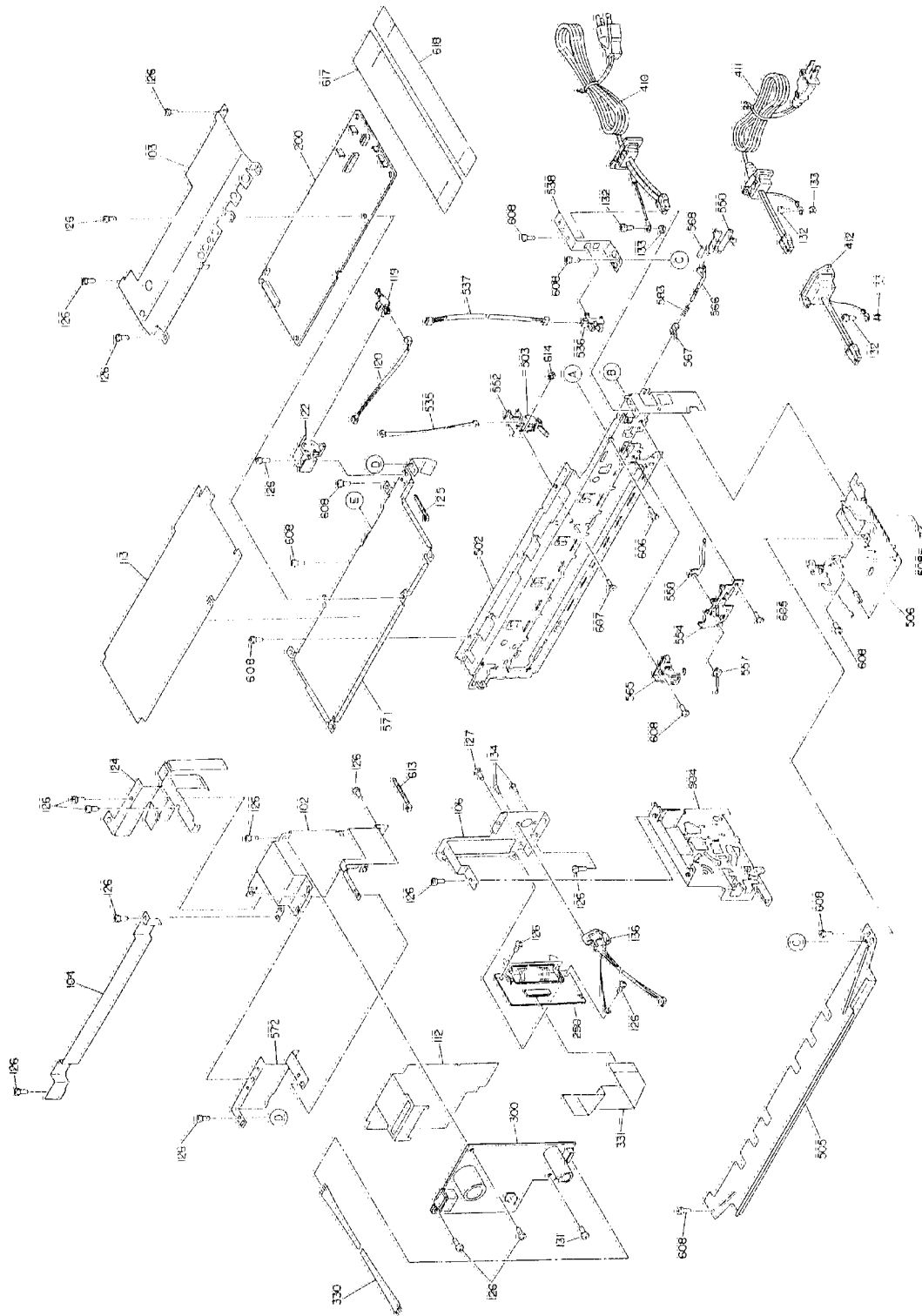

Figure A-9. EPSON Stylus Color 200 Exploded Diagram (2)

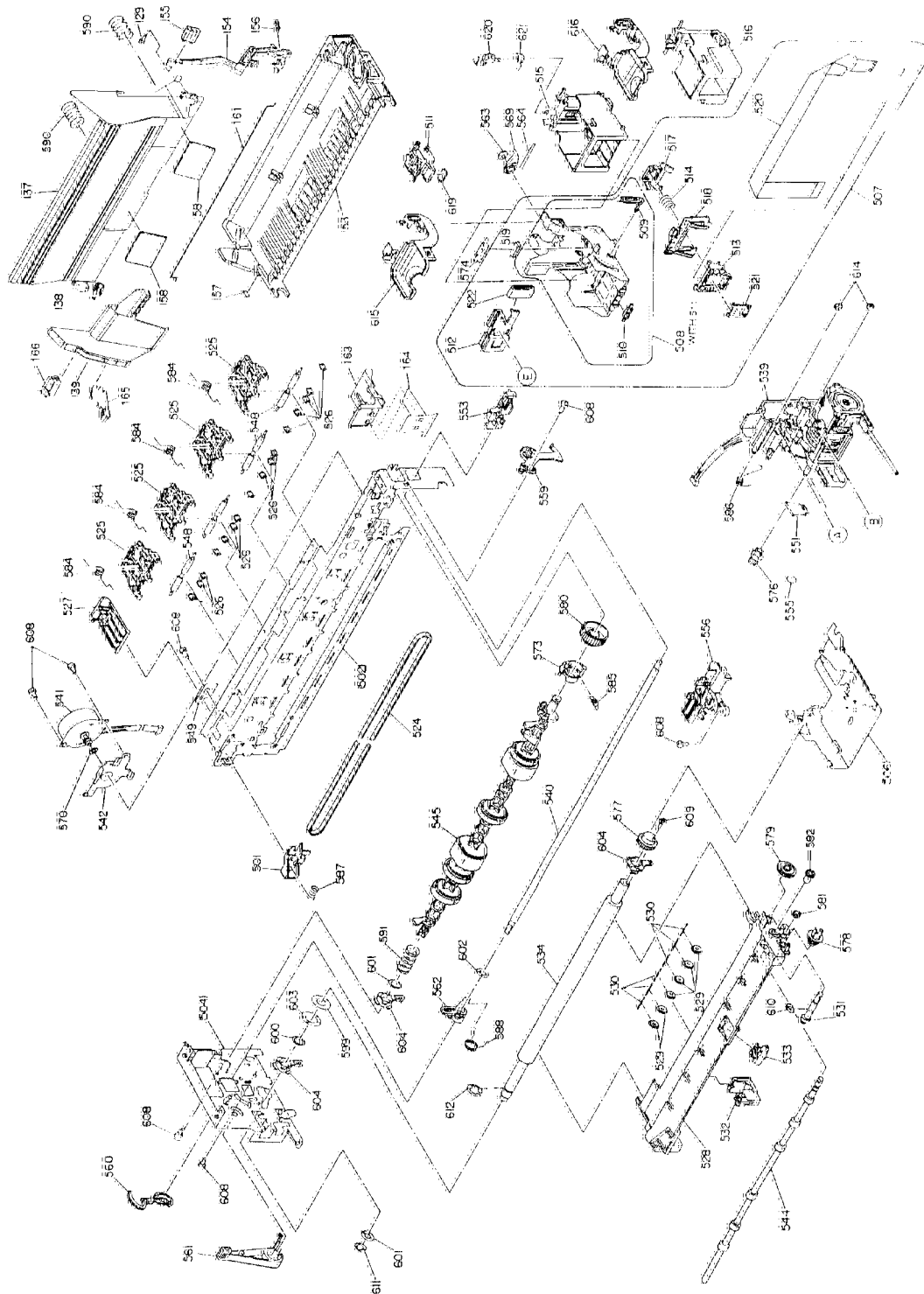

Figure A-10. EPSON Stylus Color 200 Exploded Diagram (3)

EPSON